

Owner's Manual (Additional Vol.)

Network Set-up and Operation

Wired and Wireless Setting
Projector Controller
Network Viewer
Moderator Function

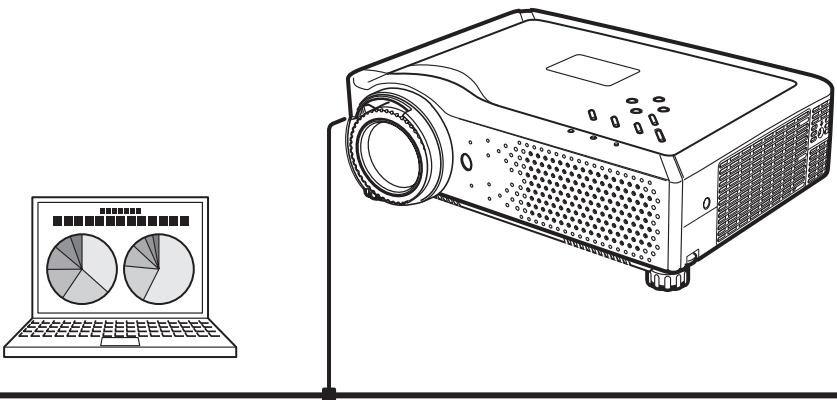

First, read the owner's manual of the projector to understand the projector's basic operation and the safety instructions.

The safety instructions in the owner's manuals should be followed.

Compliance

Federal Communication Commission Notice

This equipment has been tested and found to comply with the limits for a Class B digital device, pursuant to part 15 of the FCC Rules. These limits are designed to provide reasonable protection against harmful interference in a residential installation. This equipment generates, uses and can radiate radio frequency energy and, if not installed and used in accordance with the instructions, may cause harmful interference to radio communications. However, there is no guarantee that interference will not occur in a particular installation. If this equipment does cause harmful interference to radio or television reception, which can be determined by turning the equipment off and on, the user is encouraged to try to correct the interference by one or more of the following measures :

- Reorient or relocate the receiving antenna.
- Increase the separation between the equipment and receiver.
- Connect the equipment into an outlet on a circuit different from that to which the receiver is connected.
- Consult the dealer or an experienced radio/TV technician for help.

Use of shielded cable is required to comply with class B limits in Subpart B of Part 15 of FCC Rules.

Do not make any changes or modifications to the equipment unless otherwise specified in the instructions. If such changes or modifications should be made, you could be required to stop operation of the equipment.

Model Number	: XG-705A
Trade Name	: Sanyo
Responsible party	: SANYO FISHER COMPANY
Address	: 21605 Plummer Street, Chatsworth, California 91311
Telephone No.	: (818)998-7322

For Canadian Users

This Class B digital apparatus complies with Canadian ICES-003.

Cet appareil numérique de la class B est conforme à la norme NMB-003 du Canada.

L'utilisation de ce dispositif est autorisée seulement aux conditions suivantes : (1) il ne doit pas produire de brouillage et (2) l'utilisateur du dispositif doit être prêt à accepter tout brouillage radioélectrique reçu, même si ce brouillage est susceptible de compromettre le fonctionnement du dispositif.

CAUTION

Changes or modifications not expressly approved by the manufacturer could void the user's authority to operate the equipment.

Exposure to radio frequency

This product uses a USB Wireless LAN Adapter to communicate with other devices using the 2.4 GHz ISM band. The radiated power output of this card is well below FCC radio frequency exposure limits. However, it is advised to maintain a minimum 20 cm separation between the product and user(s) or bystanders to minimize human exposure to the transmitted radio frequencies.

For French Users

Restricted frequency band only channels 10 through 11 (2457MHz and 2462MHz respectively) may be used in France. License required for every installation, indoor and outdoor installations.

Please contact ART for procedure to follow. Do not use this USB Wireless LAN Adapter in the open air.

Statement on EC Directive

Hereby, SANYO Electric Co., Ltd., declares that this USB Wireless LAN Adapter (XG-705A) is in compliance with the essential requirements and other relevant provisions of Directive 1999/5/EC.



The CE Mark is a Directive conformity mark of the European Community(EC).



The Alert Mark is a Directive conformity mark of the European Community.

Safety Instructions



CAUTION IN USING THE PROJECTOR VIA NETWORKS

- When you find a problem with the projector, remove the power cable immediately and inspect the unit. Using the projector with failure may cause fire or other accidents.
- If you remotely use the projector via networks, carry out a safety check regularly and take particular care to its environment. Incorrect installation may cause fire or other accidents.



CAUTION IN USING NETWORK FUNCTION

- SANYO Electric Co., Ltd. assumes no responsibility for the loss or damage of data, or damage of the computer caused by using this projector. Making back-up copies of valuable data in your computer is recommended.

Caution about Radio Wave

This unit operates in 2.4 GHz band, the same frequency band used for industrial, scientific, and medical equipment (such as pacemaker), as well as amateur radio stations.

Please read “Safety Instructions” section and make sure the following cautions.

1. Be sure that there are no other devices in the area that may use the same frequency band as Projector.
2. If any other devices are causing radio interferences, change the communication frequency channel or move to other location.

Trademarks and Copyright

Microsoft, Windows, and Internet Explorer are either registered trademarks or trademarks of Microsoft Corporation in the United States and/or other countries.

Netscape Navigator and Netscape Communicator are registered trademarks or trademarks of Netscape Communications Corporation in the United States and other countries.

Pentium is a registered trademark of Intel Corp. in the United States.

Each name of corporation or product in this Owner’s Manual is either a registered trademark or a trademark of its respective corporation.

Notes

- The contents of this manual are subject to change without notice.
- You may not copy the printed materials accompanying with the software.
- We shall not be responsible for any damages caused by reliance on this manual.

Table of Contents

Compliance.....	2
Safety Instructions.....	3
Table of Contents.....	4
Operating Environment and Configuration.....	6
Required Operating Environment for Computers.....	6
Network Specifications of the Projector.....	7
1. About LAN Functions.....	9
LAN Functions and the Features.....	10
Image Projecting System via LAN.....	10
Flow of Image Transfer.....	10
An Example of the Connection.....	11
LAN Connection Modes.....	12
2. Setup Procedures.....	15
Installing the Software.....	17
3. Names and Functions of the Operation Screen.....	19
Network Connection Standby Display.....	20
NetworkModule Client.....	21
NetworkModule Moderator.....	23
4. Wired LAN Configurations.....	25
Connecting to the LAN Line.....	26
Network Environment Settings.....	26
Setting Procedure.....	26
Confirming the Operation.....	28
User PIN Code / Wired Information / Wired Factory Default.....	30
Factory Default Setting of the Wired LAN.....	31
5. Wireless LAN Configurations.....	33
Attaching the USB Wireless LAN Adapter.....	34
Setting the Network Environment.....	34
Setting Procedures.....	34
Easy Setting.....	36
Setting Procedures.....	36
User PIN Code / Wireless Information / Wireless Factory Default.....	37
Wireless LAN Factory Default Settings.....	38
6. Configurations with Browser.....	39
Introduction.....	40
Browser Environment.....	40
Browser Configuration.....	40
Starting up the Browser.....	41
Information.....	42
Quick Setup.....	44

Advanced Setup	46
TCP / IP	46
Wireless Setting	47
E-mail	48
Admin Password	49
User PIN code	50
Moderator Login Password	51
Miscellaneous	52
Change Configuration Set	53
Restart	54
7. Project the Image via the Networks	55
8. Use the Moderator Function	57
Moderator Function	58
Preparation for Using the Moderator Function	59
Preparation Procedure for Using the Moderator Function	59
Setting the Moderator Function	60
Registration of the Moderator	60
Registration of the Clients (Participants)	61
Unregister from Moderator Status	62
How to Use the Moderator Function	62
Project the Client's Images	62
Stop Projecting the Client's Images	62
Easy Settings for Moderator Function	62
9. How to Use Network Viewer	63
The Mechanism of Network Viewer and the Flow of the Signal	64
Operation	65
Functional Conditions of FTP Server Which Provides Images	65
Projecting the Image	66
10. How to Use the PJ Controller	73
How to Operate	74
Initial Settings	75
E-mail Setting	76
Power & Status	78
Control	80
Multi Control	89
11. Appendix	91
Troubleshooting	92
Terminology	95
Setting up the IP address with "arp" + "ping" command	96

Operating Environment and Configuration

Required Operating Environment for Computers

When operating the projector via the networks, computers should meet the operating environment below.

OS	Microsoft Windows 98SE/Me or Microsoft Windows 2000 Professional or Microsoft Windows XP Home Edition/Professional	
CPU	Pentium III 600MHz or More (more than 2GHz is recommended)	
Memory	128MB or More	
Free HDD Space	10MB	
Screen Resolution	Required to support any of VGA(640X480), SVGA(800X600), XGA(1024X768), The color number should be either 16 byte(65536 colors) or 24/32 bit(16.77 million colors).	
Communication Protocol	TCP/IP	
Network Correspond	Wireless LAN	Correspond to IEEE802.11b/g
	Wired LAN	Correspond to 100BASE-TX (100Mbps) /10BASE-T (10Mbps)
Browser Application	Microsoft Internet Explorer Ver.4.0 or later Netscape Communications Netscape Communicator Ver.6.0 or later	

Network Specifications of the Projector

LAN Terminal

Data communication speed	100Base-TX(100Mbps)/10Base-T(10Mbps)
Protocol	TCP/IP

USB Wireless LAN Adapter

Interface	Correspond to IEEE802.11b/g, USB 2.0 / 1.1
Communication Mode	AdHoc, Infrastructure
Data Transfer Speed	1/2/5.5/11Mbps(IEEE802.11b) 6/9/12/18/24/36/48/54Mbps(IEEE802.11g) When using AdHoc mode, only IEEE802.11b is usable.
Wireless Frequency (Channel)	2412MHz-2462MHz (CH1-CH11)
Modulation Form	IEEE802.11g OFDM 54/4Mbps 64QAM, 36/24Mbps 16QAM, 18/12Mbps QRSK, 9/6Mbps BPSK IEEE802.11b DSSS1 11/5Mbps CCK, 2Mbps DQPSK, 1Mbps DBPSK
Protocol	TCP/IP
Security	WEP 64 Bit/WEP 128Bit/WEP 152Bit,SSID,ESSID, LEAP
Service area	about 30m(without disturbance) Differs according to the operating environment.
Operating Voltage	DC 5V
Environmental conditions	Operating temperature : 5-35°C Storage temperature / Humidity :10-60°C/5-95%

Compliance

Countries and Standards	JAPAN: VCCI ClassB,TELEC(Wireless)
	USA: FCC Part15 Subpart C (Wireless) FCC Part15 Subpart C, Class B
	Canada: IC RSS-210(Wireless), IC ICES-003 ClassB
	Europe: R&TTE, EMC, LVD

1. About LAN Functions

This chapter describes the features, the mechanism, and connection procedures of the LAN.

1. About LAN Functions

LAN Functions and the Features

This product is loaded with a LAN network function which enables you to project an image on the computer through a projector via Network with dedicated software.

With the software, you can also manipulate the projecting image and the projector.

This software has functions below and you can use the projector under various network environments to meet the wide-ranging needs of the operation.

- Accept both Wired and Wireless LAN environment. When operating via Wireless LAN, there is no need for wire connection.
- Remove the burden of LAN settings. Easy LAN setting function is provided.
- One computer image can be projected up to 5 projectors simultaneously.
- Project the faithful computer image without any influence by the application.
- Remote function which allows you to operate the projector from a distance.
- Monitoring function for the projector operation.
- E-mail function which reports the operating status to your maintenance management.
- Network viewer function which remotely operates the image data on the server to project through the projector.
- Moderator function with which the moderator can project the image on the participants' computer screen at the meetings or the classes.
- Multi control function which can operate multiple projectors (up to 64) simultaneously.

Image Projecting System via LAN

The images are projected through an image capturing system which helps to project the faithful computer images. With this system, you can use the product under various application environments despite the differences of application software.

Flow of Image Transfer

1. Download the computer image with the dedicated software faithfully to the real image.
2. The downloaded data will be compressed to the digital signal and transferred to the projector via the LAN (Wired or Wireless). (One computer can operate up to 5 projectors simultaneously.)
3. Digital signal will be reproduced into RGB image signal and will be projected by the projector.

* The image will be transferred to each projector. The time lag can occur between each projection.

CAUTION: This product does not correspond to the application with DirectX, MS-Office assistant, and video replay such as DVD.

An Example of the Connection

The illustration below shows an example of the projection via the LAN.

You can project the image on Computer (1) (Wired LAN connection), or Computer (2) (Wireless LAN connection) through the selected projector .

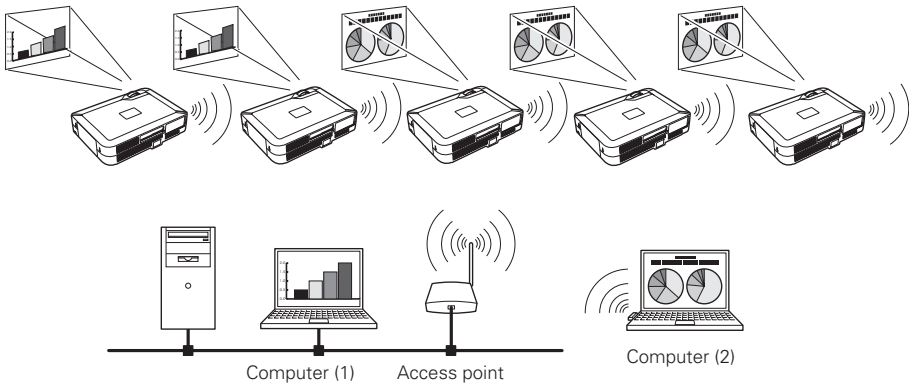

LAN Connection Modes

.....

Connection modes differ depending on the LAN and computer environments.
Connect appropriately for each environment.

■ Wireless LAN, Infrastructure Communication Mode

Communicate over an access point between Wired LAN equipment and Wireless LAN equipment. Or, communicate over an access point among multiple Wireless LAN equipment. Wireless LAN equipment will select an access point to communicate SSID/ESSID modes. These the communication modes are used when both Wireless LAN and Wired LAN are used in the same network environment.

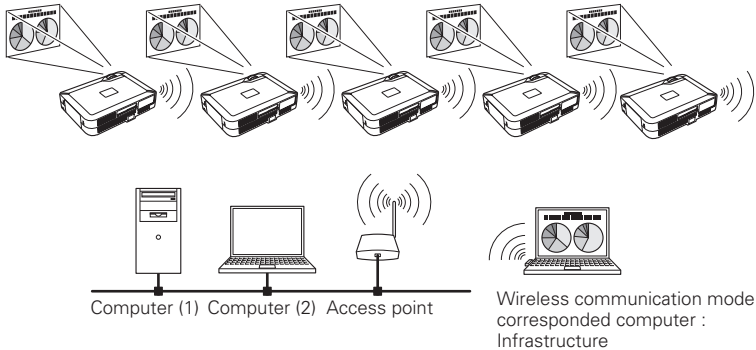

■ Wireless LAN, AdHoc 802.11b Communication Mode

Communication mode between Wireless LAN equipment.
(Communication mode via SSID/ESSID)

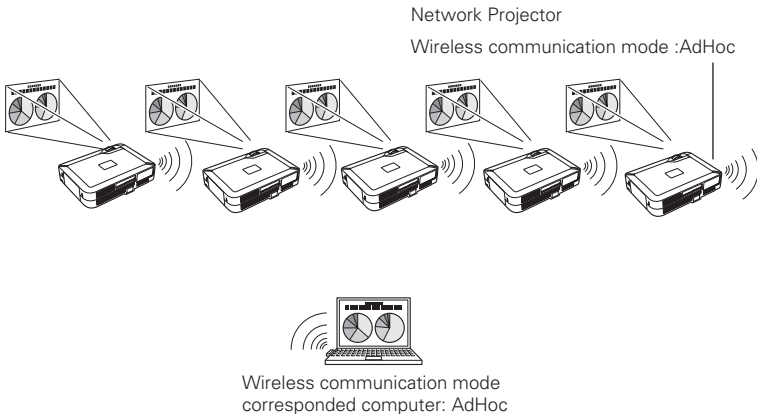

■ Wired LAN Communication Mode

Communicate via the LAN line.

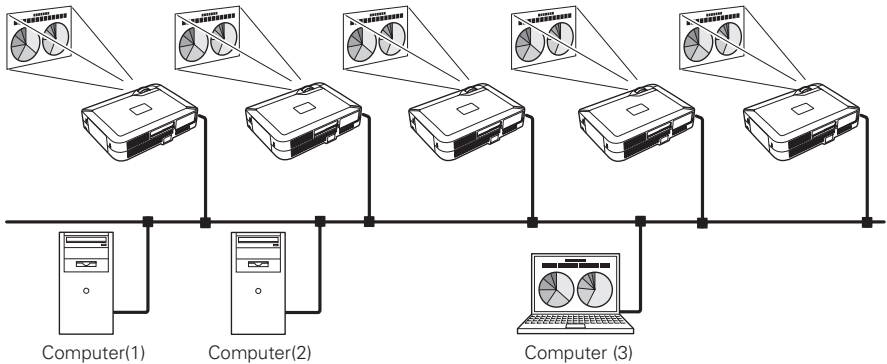
*** Operate the computer mouse with the remote control.**

When the projector's remote control employs mouse operating function, you can operate the computer by the remote control which is provided with the projector. Use the remote control pointing to the projector. You do not need to connect the USB cable to operate the computer mouse.

(For details about the remote control operation, refer to the owner's manual of the projector.)

2. Setup Procedures

This chapter describes how to install the NetworkModule software and how to set up the networks.

2. Setup Procedures

To use the projector via the networks, follow the setup procedures below.

STEP 1 Install the software on computers.



Install the software recorded in CD-ROM on each computer which will be operated. Read following pages of this chapter to install.

STEP 2 Select Wired LAN or Wireless LAN then connect the LAN and set the configuration.



Decide depending on the LAN environment.

Wired LANRefer to "4. Wired LAN Configurations" (p25-31)

Wireless LAN ...Refer to "5. Wireless LAN Configurations" (p33-38)

Detailed LAN configurations need to be done with a browser later.

First, complete the Wired or Wireless LAN connection between computers and projectors, then start browser configurations.

→ "6. Configurations with Browser". (p39-54)

STEP 3 Network Configuration has completed.

Follow each chapter to project an image and operate the projector.

- Project an image on the computer
 - "7. Project the Image via the Networks" (p55-56)
- Project an image with the moderator function
 - "8, How to Use Moderator Function" (p57-62)
- Project an image on a network server
 - "9. How to Use Network Viewer" (p63-71)
- Operate and manage the projector
 - "10.How to Use PJ Controller" (p73-88)
 - Multi Control Function (p89-90)

Installing the Software

Three pieces of software is recorded in the supplied CD-ROM.

1. Insert the CD-ROM into the drive.

The software will be activated automatically and "Software License" screen will be displayed. Read the license carefully and if you agree, check "Agree" then click "OK".

When the screen is not displayed automatically, open "CD-ROM Drive" in "My computer" of your computer to activate "AutoRun. exe". The software can be displayed both in Japanese and English. When the English version does not appear, open the English folder in the CD-ROM and double-click "AutoRun. exe" in it.

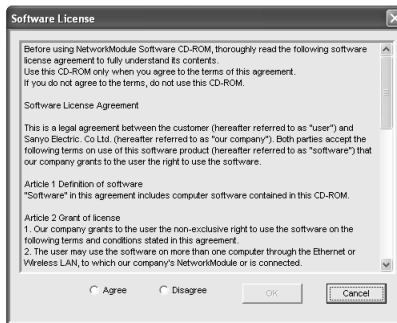

2. Main menu will be displayed on the screen.

Three software names will be shown on the left side of the screen. Refer to the instructions below and select the most suitable software for you.

■ When projecting via a selected computer which is connected to the LAN.

Install "NetworkModule Client".

- (1) Click (Select) "NetworkModule Client" on the left side of the screen.
- (2) Click "Install NetworkModule Client" on the right side of the screen then move to the step (4).

* By clicking the "Activate NetworkModule Client", you can activate the software directly from the CD-ROM without installing the software into the computer.

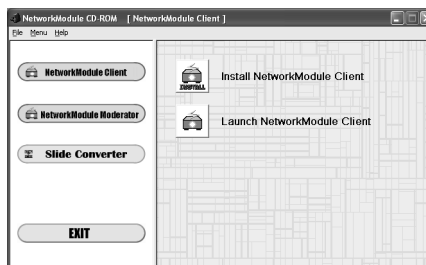

2. Setup Procedures

■ When projecting with the Moderator function.

For details about Moderator function, refer to the "8. Use the Moderator Function".

- (1) Install "NetworkModule Client" into each client's (participants except for the moderator) computers. For installation, refer to "■ When projecting via a selected computer which is connected to the LAN". (p17)
- (2) Click (Select) "NetworkModule Moderator" on the left side of the screen.
- (3) Click "Install NetworkModule Moderator".

* By clicking the "Activate NetworkModule Moderator", you can activate the software directly from the CD-ROM without installing the software into the computer.

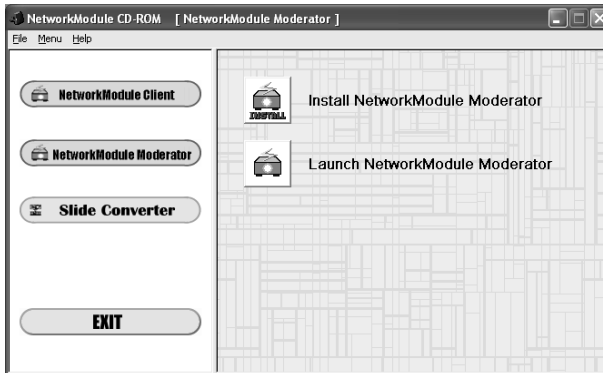

- (4) Install each software with following the instructions on the installation screen.
- (5) After the installation, the start-up menu will be displayed or the program icon will be added on the screen.
- (6) Activate the program to confirm the installation. When the program is activated, the operation screen will appear.

Refer to "3. Names and Functions of the Operation Screen" (p19-23) to operate each program screen.

To uninstall (delete) each program, activate the uninstall program in the application start menu.

3. Names and Functions of the Operation Screen

This chapter describes the functions of each part of the operation screen.

3. Names and Functions of the Operation Screen

Network Connection Standby Display

Select projector input either "Wired" or "Wireless" and the Network connection standby display will appear. Network environment will be shown on the screen. With this screen, you can confirm that the network connection is whether "Wired" or "Wireless", or network environment of the projector when setting the connection.

After selecting "Wired" or "Wireless", "Please wait..." message will appear and then change into "Ready for use" message to show the network is ready to project. While "Please wait..." message is showing, you cannot operate the projector.

You can select to display or not to display the Status bar (shows network environment) from "6. Configurations with Browser" → "Advanced Setup" → "Miscellaneous". (p52)

Network Connection Standby Display
(※ The screen below is for the Wireless LAN setting)

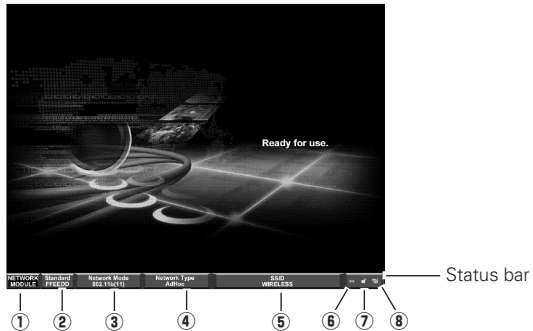

① NETWORKMODULE

"NETWORKMODULE" is the projector on the networks.

② The lower stand numbers show last 6 characters of a MAC address.

③ Display the Network Mode.

Auto(10/100M) is for Wired mode, 802.11b(11) / 802.11g(11) is for Wireless mode.

④ Display the Network Type.

"Wired" for Wired mode, "AdHoc" or "Infrastructure" for Wireless mode.

⑤ SSID (Only for Wireless LAN)

Display the Wireless LAN ID which is set on the projector.

⑥ Packet receive display

Display the communication status of the projector.

When the display is blinking, the projector is properly connecting with the network.

When the display is not blinking, the projector is not connecting to the network.

⑦ Display whether the WEP(Encryption) is effective or ineffective.

The unlocked display means not encrypted, the locked display means encrypted.

(For Wired LAN, unlocked illustration will appear.)

⑧ Display the signal level.

Display the signal level of the Wired and Wireless. When the signal level is strong, there will be more vertical lines and the signal level is low, there will be less vertical lines.

NetworkModule Client

This software is to project the computer screen via the networks.

To use the moderator function, install this software into each participant's (except for the moderator) computers.

Activate "NetworkModule Client" from the application start menu or the shortcut on the desk top, then following screen will appear. Then the program will start.

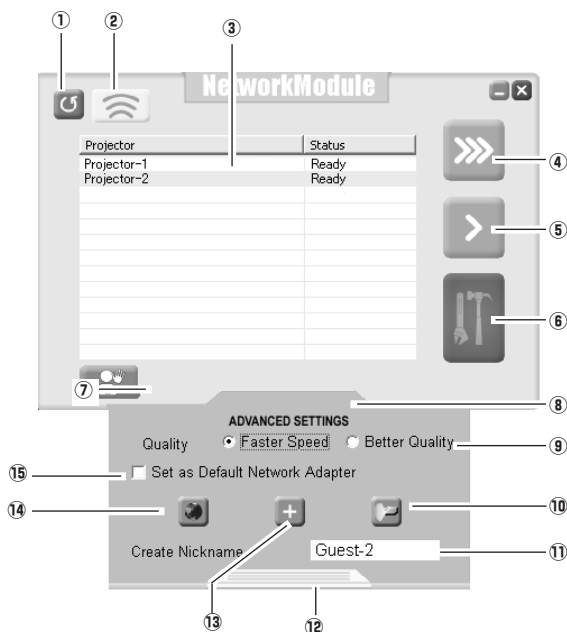

Parts Names and Functions of the Screen

① Refresh List button

Search the projector connected to the networks.

② Locator button

Click the button after selecting a projector from the Network Projector List, the operated computer's nickname will be displayed on the upper part of the projected screen for a certain period. With this function, you can identify each projector.

③ Network Projector List

Display all the projectors connected to the networks.

Show unoccupied projector as "Ready" and occupied projector as "In-use". When registered in a moderator's group, the projector is shown in pink characters.

④ Real time Capture button

Capture (Project) the computer screen in real time. After capturing, the button will change into the Stop Capture button. Click the Stop Capture button, then the projection will stop and the screen will disappear.

⑤ One-shot Capture button

Copy and capture (project) the computer screen without modification. After completing the image transmission, the communication will stop and you can operate other functions.

⑥ Easy Setting button

Configure the Wireless LAN settings just clicking this button. (The settings will be stored as AdHoc system) For details, refer to "5.Wireless LAN Configurations" → "Easy Setting". (p36-37)

⑦ Join the moderated session button

Enter the moderator's group which is selected in the Network Projector List.

Advanced Settings

⑧ Advanced Settings button*

Display the Advanced Settings.

⑨ Quality selection

Select the speed and picture quality of the screen to capture.

Faster Speed —— Screen capturing will be speedy but the picture quality will be lower.

Better Quality—— Screen capturing will be slower but the picture quality will be better.

⑩ PJ Controller / Multi control button

Start up the operation screen of the projector. Refer to "10. How to Use the PJ Controller". (p73-90)

⑪ Create Nickname box

Create a nickname for each participant. When using moderator function, each computer's nickname (up to 16 characters) will be displayed on the client list of the moderator's screen allowing moderators to recognize the participants.

⑫ Close button

Close Advanced Settings. (After closing the Advanced Settings menu, the settings you have made in ⑨⑪⑮ will be effective.)

⑬ Add NetworkModule button

When connecting the projector which is not displayed on the "Network Projector List", because it is separated by the router, click the button to set the connection. Refer to "4. Wired LAN Configurations" → "Confirming the Operation". (p28-29)

⑭ Configure NetworkModule button

For setting the networks with the browser. Refer to "6. Configurations with Browser". (p39-54)

⑮ Set as Default Network Adapter box

When using multiple network adapters with a computer, check here then the selected adapter will always be used with the software. After exiting the software, the selected adapter will be cancelled.

*The ⑨⑪⑮ settings you have made in ⑧Advanced settings will not be effective until closing the menu screen with ⑫Close button.

NetworkModule Moderator

When using the moderator function, install the software on the moderator's computer. The function is the same as "NetworkModule Client" and on top of it, the moderator function is added.

Activate "NetworkModule Moderator" from the application start menu or the shortcut on the desk top, then following screen will appear. Then the program will start.

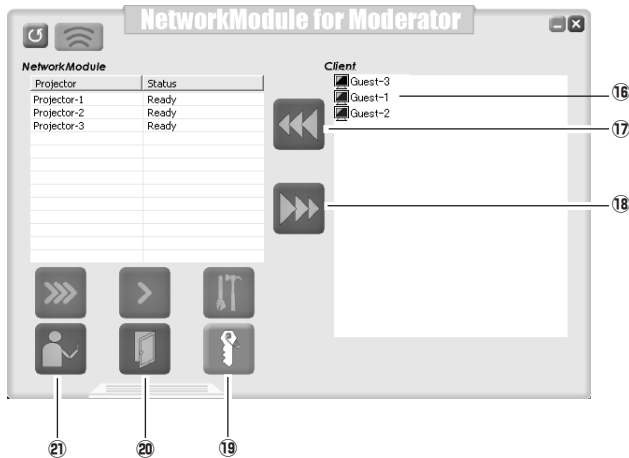

Parts Names and Functions of the Screen

Refer to "NetworkModule Client" (p21-22) about functions which are not written below.

- 16 Moderator Client List Screen**
 Clients (participants) who joined the moderator's group will be shown. The moderator selects one of the participants from the list to project his/her computer screen. When the clients have nicknames, the names will be shown.
- 17 Start Remote Capture button**
 Start capturing the image of the participants and send it to the projector. The image will be sent in real time.
- 18 Stop Remote Capture button**
 Stop capturing the image of the participants.
- 19 Set Session Password**
 Set or modify the Session Password.
- 20 Exit moderator status button**
 Unregister the moderator.
- 21 Moderator login button**
 Register the computer user as a moderator.

4. Wired LAN Configurations

This chapter describes the preparation for Wired LAN setting with projectors and how to set the LAN environment.

4. Wired LAN Configurations

Setting procedures and contents differ depending on the LAN installation location. When installing, consult your system administrator to set up the LAN appropriately.

Connecting to the LAN Line

Connect the LAN cable to the LAN connection terminal of the projector.

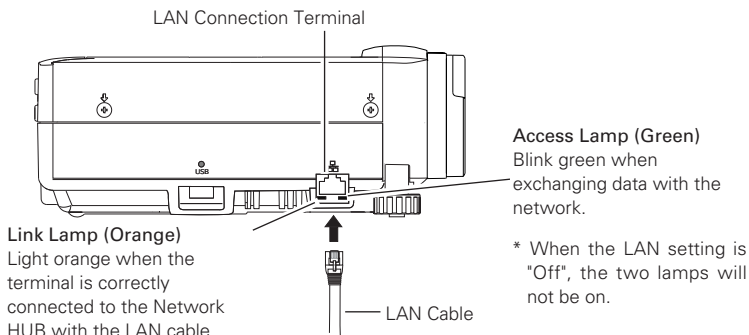

Network Environment Settings

Set the Wired LAN network through the projector menu.

Detailed network settings will be made with browser. Refer to "6. Configurations with Browser". (p39-54)

First, complete the settings described in this chapter before performing steps in "6. Configurations with Browser".

Setting Procedure

1. Turn on the projector and select "Wired" from the input menu of the projector.
The projector's Link Lamp will be on and the Access Lamp will start to blink. If the "Wired setting" is "Off", it will not blink. Follow step 2 and 3 to blink the lamp.
2. Select "Wired Setting" in the projector menu, and press the SELECT button.
Select similar LAN environment among LAN1, 2 and 3 with the Point ◀▶ buttons. (LAN1, 2, and 3 are the factory default setting environments. You can select three different environment among setting LAN1-3. For each setting, refer to the chart on page 31.)
When selecting "Off" in the "Wired setting", the LAN connection will be cut off. Use the function when disconnecting the projector from the network.
3. Press the Point button then "Please wait..." message will appear and switching operation will start. Switching will take a while and after completing the operation, the "Ready for use" message will appear. During the switching period, the projector cannot be operated.

4. Press the SELECT button.

LAN setting screen will appear and selected LAN settings will be displayed. Adjust each item to the setting environment. Consult your system administrator about the detailed settings.

Adjust the figures with the Point ▲▼ buttons and move among the items with the Point ◀▶ buttons.

5. After completing all the settings, select "Set" and press the SELECT button. Now, all procedures has done. To cancel the adjusted settings, select the CANCEL button before clicking the SET button.

To confirm whether the settings are correct, follow the procedures from the next page.

You can confirm the LAN settings you have made from "Wired Information". (p30) As in the case that the LAN cannot be connected, see this screen.

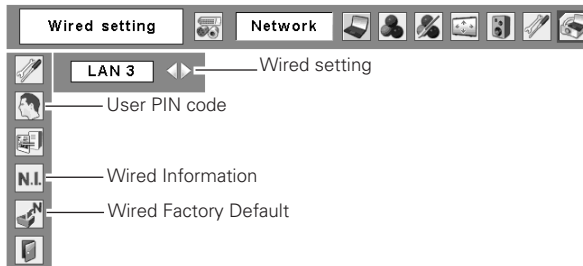

Wired LAN setting screen (Example)

LAN1		Wired setting			
IP address		192	168	1	201
Sub net		255	255	255	0
Gateway		192	168	1	1
DNS		0	0	0	0
		Set		Cancel	

Confirming the Operation

Confirm that the projector has connected to the LAN properly.

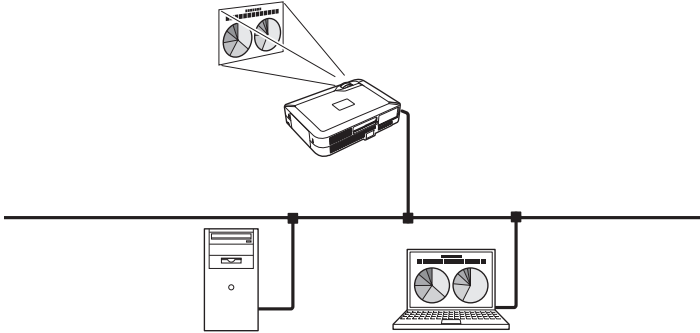

1. Activate "NetworkModule Client" or "NetworkModule Moderator" which is installed into the computer connected to the LAN .
2. After appearing "NetworkModule searching" message, the name of the projector* appears on the Network Projector List, then the network setting has completed properly.

When the name of the projector does not appear and error screen appears, the network has not connected yet. Try searching again with the Refresh List button. If error screen appears again, reconfirm the LAN setting. When the projector is set where separated by the router, see next page.

When Firewall function (Anti-virus software) is effective, network projector may not be found. In that case, disable the Firewall function and try searching again.

* If the projector is named, the name will be displayed. The name can be set with following the procedures in "6. Configurations with Browser" → "Quick Setup" (p44-45) or "Advanced Setup" → "Miscellaneous" (p52). If the projector is not named, MAC address of the projector will be displayed.

NetworkModule Client screen

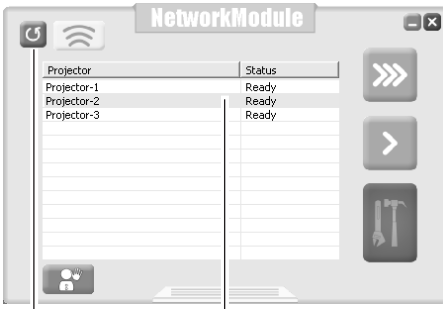

Refresh List button Network Projector List

Error screen

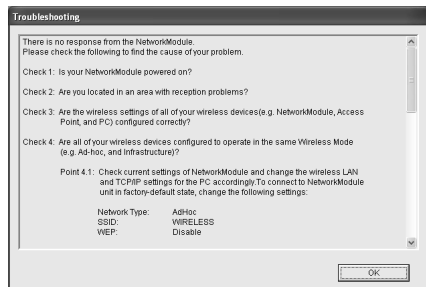

When set up the projector where separated by the router and the segment is different; Projector will not be found nor displayed. In this case, the projector needs to be searched directly by the IP address.

1. Click the Add NetworkModule button in the Advanced Settings menu. The Add NetworkModule screen will appear.
2. Click "Add" then the IP address screen will appear. Enter the IP address and click "OK". The projector will be added on the Add NetworkModule screen. If you check "Check status", the connected projector will be checked periodically.
3. Click "OK" then the projector will be added on the Network Projector List.

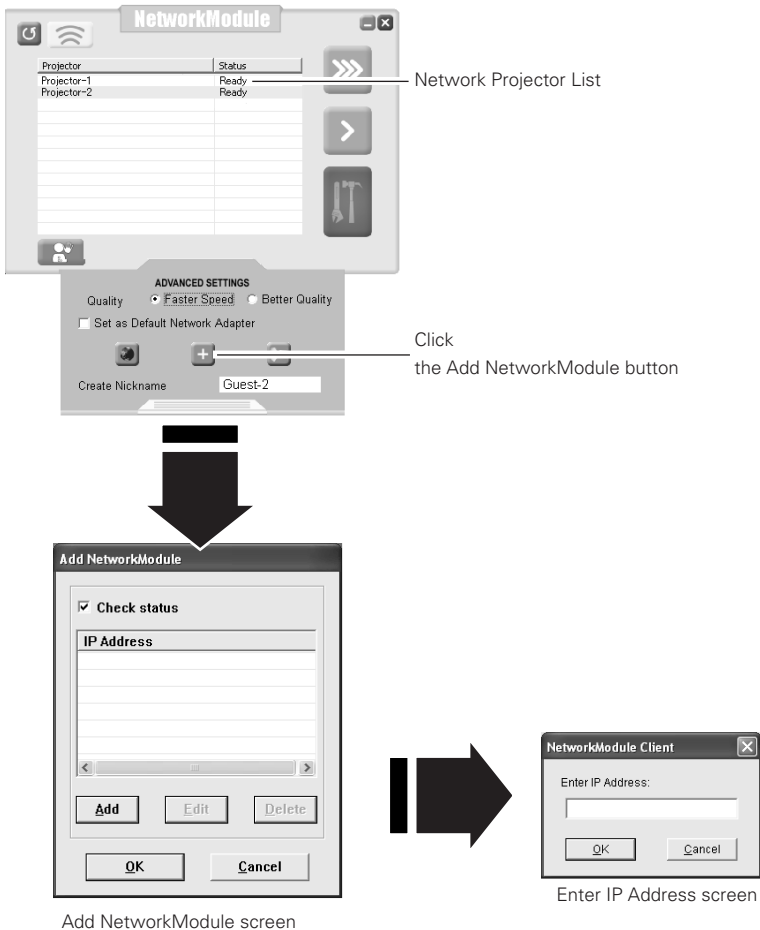

User PIN Code

The User PIN code is to restrict the access from the networks to the projector. After setting the User PIN code, you need to enter it to operate the projector via the networks.

1. Select User PIN code, and press the SELECT button.
The User PIN code screen will appear.
2. Set the User PIN code.

Set the figures with the Point ▲▼ buttons and move to the next items with the Point ◀▶ buttons. Select "Set" and press the SELECT button to set. To cancel the preset User PIN code, select "Cancel". When you do not want to set the User PIN code, set "0000".

It is recommended to set the User PIN code if you use the projector via the networks. You can also change the User PIN code. See "6. Configurations with Browser" → "Advanced Setup" → "User PIN code". (p50)

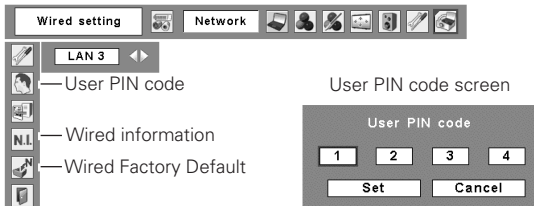

Wired Information (See the menu above.)

Select Wired information from the projector menu and press the SELECT button to show LAN setting environment of the currently selected projector. (The description below is an example and different from what will be shown.)

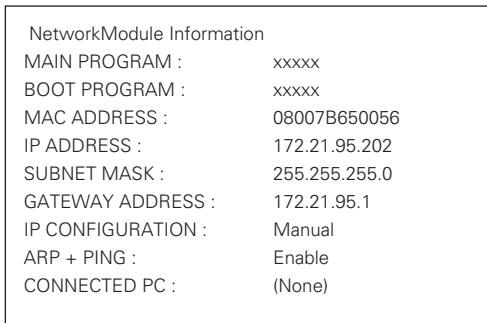

Wired Factory Default (See the menu above.)

Return all the Wired LAN settings to the factory default settings which are shown on the next page.

Factory Default Setting of the Wired LAN

Parameter	SELECTED LAN		
	LAN1	LAN2	LAN3
IP ADDRESS	169.254.100.100	192.168.100.100	192.168.100.100
SUBNET MASK	255.255.0.0	255.255.255.0	255.255.255.0
GATEWAY ADDRESS	255.255.255.255	255.255.255.255	255.255.255.255
DNS ADDRESS	255.255.255.255	255.255.255.255	255.255.255.255
IP CONFIGURATION	MANUAL	DHCP	MANUAL
INTERRUPT CONNECTION PERMISSION	ENABLE	ENABLE	ENABLE
IP CONFIGURATION with ARP+PING	ENABLE	ENABLE	ENABLE
DNS DOMAIN	-	-	-
SYSTEM PASSWORD	BLANK	BLANK	BLANK
USER PIN CODE	0000(NONE)	0000(NONE)	0000(NONE)

These settings can be made only by the browser.
Refer to "6. Configurations with Browser". (p39-54)

5. Wireless LAN Configurations

This chapter describes the preparation for Wireless LAN setting with projectors and how to set the LAN environment.

To operate via Wireless LAN, attach the USB Wireless LAN Adapter to the projector.

The setting procedures and configurations differ depending on the LAN installation location. Consult your system administrator for installation and set the LAN appropriately.

To operate via Wireless LAN, your computer has to be equipped with a Wireless LAN card adapter which supports IEEE 802.11b/g.

If connecting in Infrastructure mode with an access point, the access point is required to support IEEE 802.11b/g.

Caution : Do not use a mobile phones or PHS near (within 20cm / 8inch) the projector. It may cause malfunction.

5. Wireless LAN Configurations

Attaching the USB Wireless LAN Adapter

Insert the USB Wireless LAN Adapter into the USB terminal of the projector. Inserting the adapter after verifying the shape of the connector in order not to break the terminal.

CAUTION: Use specified USB Wireless LAN Adapter. If you use other product, the projector will not be operated properly.

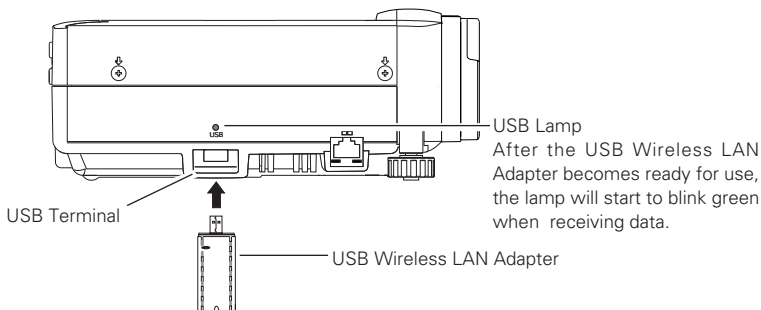

Setting the Network Environment

Set the Wireless LAN network through the projector menu.

Detailed network settings will be made with browser. Refer to "6. Configurations with Browser". (p39-54) Complete the settings described in this chapter before performing the steps in "6 Configurations with Browser".

Setting Procedures

With Easy setting, you can make Wireless LAN settings easily without any complicating settings. (p36)

1. Turn on the projector and select "Wireless" from the input menu of the projector. The Network connection standby display will appear and "Please wait..." message will be displayed. Refer to "3.Names and Functions of the Operation Screen" → "Network Connection Standby Display". (p20)

After short time, the message changes to " Ready for use". If the USB Wireless LAN Adapter is not attached to the projector, "Wireless" cannot be selected.

2. Select "Wireless Setting" from the projector menu and press the SELECT button.

Select similar environment between LAN 4 and LAN 5 with the Point ◀▶ buttons. (LAN 4, LAN 5 and SIMPLE* are factory default settings. Select similar environment to the installation location. For each settings, refer to the chart on p38.)

* "SIMPLE" mode is used for simple setting without complicated LAN setting procedures to connect to the Wireless LAN. See "Easy Setting" (p36-37) for details.

3. Press the Point button then "Please wait..." message will appear and switching operation will start. Switching will take a while and after completing the operation the message will disappear. During the switching period, the projector cannot be operated.

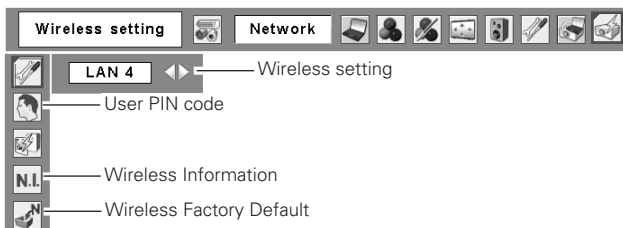

4. Press the SELECT button. LAN setting screen will appear and the selected LAN settings will be displayed. Adjust each item to the setting environment. Consult your system administrator for the detailed settings.

Adjust the figures with the Point ▲▼ buttons and move among the items with the Point ◀▶ buttons. When the network type is "AdHoc", do not have to change "Sub net" and "Gateway" and leave them as default settings.

SSID / ESSID / BSSID for the network type "Infrastructure" and "AdHoc" are required to be entered the same characters into the projector, the access point, and the Wireless LAN compatible computer. (up to 32 characters) Characters can be selected from A~Z, a~z, blank (space), 0-9, or - (hyphen) with the Point ▲▼ buttons. Move to the next character with the Point ◀▶ buttons.

You can confirm that the projector settings from "Wireless Information" in the projector menu. (p37)

* IP address can be set from the command of Windows. Refer to "11. Appendix" → "Setting up the IP address with "arp" + "ping" command". (p96)

5. After completing all the settings, select "Set" and press the SELECT button. Now, all procedures has done. To cancel the adjusted settings, select the CANCEL button before clicking the SET button..

To confirm whether the settings are correct, follow the procedures in "4. Wired LAN configurations" → "Confirming the Operation" (p28-29).

LAN4		Wireless setting	
IP address	192 . 168 . 1 . 201		
Sub net	255 . 255 . 255 . 0		
Gateway	192 . 168 . 1 . 1		
DNS	0 . 0 . 0 . 0		
Network type	ADHOC		
SSID/ESSID/BSSID			
<input type="button" value="Set"/> <input type="button" value="Cancel"/>			

Easy Setting

With this setting, you do not need any complex LAN setting procedures.
The LAN mode will be AdHoc IEEE802.11b.

CAUTION: This function can be used only when logged in by Administrative right with Windows XP. Cannot be used with Windows98SE / Me, Windows2000. Windows XP should be Service Pack 1 or later version.

Setting Procedures

1. Turn on the projector and select "Wireless" from the input menu of the projector.
2. Select "Wireless Setting" from the projector menu and press the SELECT button.
3. Select "SIMPLE" with the Point ◀▶ buttons. Press the Point button then "Please wait..." message will appear and switching operation will start. Switching will take a while and after completing the operation the message "Ready for use" will appear. During the switching period, the projector cannot be operated. ("SIMPLE" LAN settings will be shown by pressing the SELECT button. The settings cannot be changed.)
4. Activate "NetworkModule Client" or " NetworkModule Moderator" which is installed in the computer.
5. Click the Easy setting button on the operation screen. The Wireless LAN setting screen will appear and the computer will start to set up the Wireless LAN setting. (Adjust the computer's Wireless LAN environment to the "SIMPLE" setting LAN environment.)

After completing the settings, the projector will start searching the projector which was set as "SIMPLE" and will display the name of the projector or the MAC address on the projector list.

Confirm whether the LAN has been set correctly and work properly. Refer to "4. Wired LAN configurations" → "Confirming the Operation" (p28-29) for the confirmation procedures.

If the network setup is not succeeded, the error screen will appear.

Setting screen

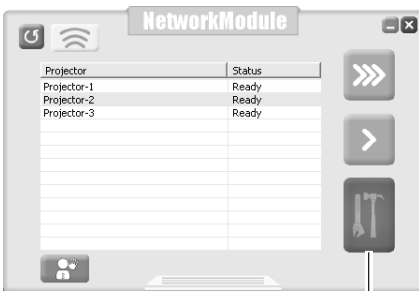

Easy setting button

Error screen

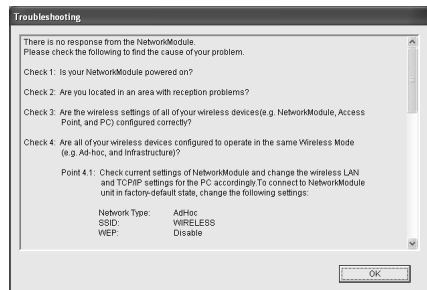

Computer environment and Wireless LAN connection;

Wireless LAN with Easy setting connection will be made via AdHoc IEEE802.11b mode. For setting contents, refer to "Wireless LAN factory default settings". (p38)

With the Easy setting, computer's LAN environment setting will be switched to the settings on p38. Because of that, the LAN cannot work for the other operation while using "NetworkModule Client" or "NetworkModule Moderator".

After terminating the application, the LAN environment will automatically go back to the previous state.

User PIN Code

The User PIN code is to restrict the access from the networks to the projector.

After setting the User PIN code, you need to enter it to operate the projector via the networks.

Select "User PIN code" from the projector menu. Set with the same procedures as setting Wired LAN User PIN code. Refer to "4. Wired LAN Configurations" → "User PIN code". (p30)

Wireless Information

Display the current LAN connecting environment. Select "Wireless Information" (p35) and press the SELECT button.

Wireless Information (Example)

NetworkModule Information	
MAIN PROGRAM :	xxxxx
BOOT PROGRAM :	xxxxx
MAC ADDRESS :	08007B650056
IP ADDRESS :	169.254.53.0
SUBNET MASK :	255.255.0.0
GATEWAY ADDRESS :	255.255.255.255
IP CONFIGURATION :	DHCP
ARP + PING :	Enable
WIRELESS MODE :	802.11b
NETWORK TYPE :	AdHoc
CHANNEL :	11
SSID :	WIRELESS
WEP :	Disable
CONNECTED PC :	(None)

Wireless Factory Default

Select "Wireless Factory Default" from the projector menu (p35) and press the SELECT button. All the LAN settings will go back to the factory default settings. For details, refer to "Wireless LAN Factory Default Settings". (p38)

Wireless LAN Factory Default Settings

Factory default settings for LAN4, LAN5, and SIMPLE as follows.

Setting Items	Selected LAN		
	LAN4	LAN5	SIMPLE
IP ADDRESS	169.254.100.100	192.168.100.100	169.254. * . *
SUBNETMASK	255.255.0.0	255.255.255.0	255.255.0.0
GATEWAY ADDRESS	255.255.255.255	255.255.255.255	255.255.255.255
IP CONFIGURATION	MANUAL	DHCP	MANUAL
INTERRUPT CONNECTION PERMISSION	ENABLE	ENABLE	ENABLE
IP Address Setting with ARP+PING	ENABLE	ENABLE	DISABLE
WIRELESS CHANNEL	11	11	11
NETWORK TYPE	802.11b AdHoc	INFRASTRUCTURE	802.11b AdHoc
WIRELESS SSID/ESSID (SSID/IBSSID)	WIRELESS (NARROW CAPS)	ANY	WIRELESS (NARROW CAPS)
WEP (WEP encryption)	DISABLE	DISABLE	DISABLE
DNS DOMAIN	-	-	-
DNS ADDRESS	255.255.255.255	255.255.255.255	255.255.255.255
SYSTEM PASSWORD	BLANK	BLANK	BLANK
USER PIN CODE	0000(NONE)	0000(NONE)	0000(NONE)
LEAP USER PASSWORD	BLANK	BLANK	BLANK

These settings can be made only from "6. Configurations with Browser". (p39-54)

These items cannot be set.

6. Configurations with Browser

The projector can be set, controlled and operated via the browser.

Caution: When operating the projector with the browser, connect the projector to the computer with Wired or Wireless LAN. Complete the connection in advance.

The browser can set or operate :

- LAN setting
Configure Wired/Wireless LAN environment.
- E-mail Setting
Configure E-mail function to manage the projector remotely.
- Operation of Network Viewer
Project and operate the image data on the network server. For details about the function, refer to "9. How to Use Network Viewer". (p63-71)
- Password Setting
Configure the security password to control the projector.
- Others
Other detailed settings.

6. Configurations with Browser

Introduction

To operate by the browser, you need to prepare and configure the environment. Check the environment of the browser and configure to operate the projector.

Browser Environment

Browser is required to support the following version.

Microsoft : Internet Explorer Ver.4.0 or later

Netscape Communications : Netscape Communicator Ver6.0 or later

Browser Configuration

Configure the operating environment of the browser. Configuration has to be accurate for proper operation.

Using Proxy Server

Internet Explorer

Start up Internet Explorer. Select "Tools" → "Internet Options". Select the "Connections" tab and click the "LAN Settings" button in the "Local Area Network (LAN) Settings" field. Click the "Advanced" button in the "Proxy Server" field. Enter the IP address set on the projector in the "Do not use proxy server for addresses beginning with" field.

Netscape Navigator

Start up Netscape Navigator. Select "Edit" → "Setup" → "Category". Select "Details" and "Proxy", and check on "Set proxy manually.". Click the "Display" button and enter the IP address of the projector in the "Proxy server is not used at address starting from the following IP address" field.

Not using Proxy Server

Internet Explorer

Start up Internet Explorer. Select "Tools" → "Internet Options". Select the "Connection" tab and click the "LAN Setup" button in the "Local Area Network (LAN) Setup" field. Check off "Proxy server is used at local address" of the "Proxy Server" field.

Netscape Navigator

Start up Netscape Navigator. Select "Edit" → "Setup" → "Category". Select "Details" and "Proxy", and check "Connect Internet directly".

6. Configurations with Browser

Information

Display the current setting environment.

The contents differ depending on Wired or Wireless LAN environment.

Screen of Wireless LAN

NetworkModule Configuration English / Access

NetworkModule for LCD Projector

LAN

MENU

- Information
- Quick Setup
- Advanced Setup
- Change Configuration Set
- Network Viewer
- Restart

Information

Firmware Version:	V0.24 (2005/04/03)
Boot ROM Version:	V0.03 (2005/05/10)
Hardware Address:	000278050205
IP Address:	192.254.100.100
Wireless Mode:	802.11b
Wireless Link Status:	Connected (94%)
WEP Security:	Disable
Current SSID:	WPELE03
Current Channel:	11
Data Transfer Rate:	54 Mbps
Current UserPC:	None
System Time:	0 days 01 14:12
Projector:	Projector-1

REFRESH

HTTP Configuration System Ver. 1.03

Screen of Wired LAN

NetworkModule Configuration English / Access

NetworkModule for LCD Projector

LAN

MENU

- Information
- Quick Setup
- Advanced Setup
- Change Configuration Set
- Network Viewer
- Restart

Information

Firmware Version:	V0.24 (2005/04/03)
Boot ROM Version:	V0.03 (2005/05/10)
Hardware Address:	000278050205
IP Address:	172.21.95.202
Current UserPC:	None
System Time:	0 days 07:37:41
Projector:	Projector-1

REFRESH

HTTP Configuration System Ver. 1.03

Parameters and descriptions of Information

Parameter	Description
Firmware Version	Show the firmware version of the projector.
Boot ROM Version	Show the boot ROM version of the projector.
Hardware Address	Show the MAC address.
IP Address	Show the IP address currently set on the projector. If DHCP is set, the IP address assigned from the DHCP server is displayed.
Wireless Mode*	Show the Communication standard 802.11b or 802.11g
Wireless Link Status*.....	Show the Wireless communication mode and its status of the projector.
WEP Security*	Show the WEP (Encryption) setting status of the projector. However, the WEP key is not shown.
Current SSID*	Show SSID set on the projector.
Current Channel*.....	Show the channel, through which the projector is currently communicating.
Data Transfer Rate*	Show the current Wireless communication speed of the projector. The communication speed is automatically changed by the environment at that time (11/5.5/2/1/54/48/36/24/18/12/9/6 Mbps). The communication speed cannot be fixed.
Current User/PC.....	Show the IP address of the computer, which is currently transferring images to the projector
System Time	Show the elapsed time since the power is turned on. The time can be reset by selecting "Reset" from the browser configuration screen, or by disconnecting power from the projector and connecting back on.
Projector.....	Show the name of projector. (Can be changed)
Refresh button	Refresh the displayed data.

* Not shown at Wired LAN setting.

Quick Setup

Set up minimum required items for operating the projector.

These settings can also be done in "Advanced Setup". (p46-52)

If you have set the items from the advanced setup, Quick Setup is not necessary.

Setting items differ depending on the Wireless LAN and Wired LAN.

To reflect the settings on the projector, click "APPLY". For details about each item/button, see next page.

When USB Wireless LAN Adapter is attached

The screenshot shows the 'NetworkModule Configuration' interface for an LCD projector. The 'Quick Setup' section is active. The 'Projector' field is set to 'Projector-1'. The 'IP Configuration Method' is set to 'Manual'. The IP settings are: IP Address: 192.254.100.100, Subnet Mask: 255.255.0.0, and Gateway Address: 255.255.255.255. The 'Wireless Mode' is set to '802.11b' and the 'Network Type' is set to 'Adhoc'. There are buttons for 'APPLY', 'REFRESH', and 'RESTORE Factory Default Settings'. The bottom right corner indicates 'HTTP Configuration System Ver. 1.00'.

When Wired LAN is connected

The screenshot shows the 'NetworkModule Configuration' interface for an LCD projector. The 'Quick Setup' section is active. The 'Projector' field is set to 'Projector-1'. The 'IP Configuration Method' is set to 'Manual'. The IP settings are: IP Address: 192.21.100.100, Subnet Mask: 255.255.255.0, and Gateway Address: 192.21.100.100. There are buttons for 'APPLY', 'REFRESH', and 'RESTORE Factory Default Settings'. The bottom right corner indicates 'HTTP Configuration System Ver. 1.00'.

Parameter	Description
Projector.....	Name each projector to distinguish it from other projectors. (up to 32 one-byte characters). The name set here will be displayed on the Network Projector List in the application operation screen.
IP Configured Method	A desired IP address setup method is selected from "Manual", "DHCP", and "BOOTP". If "DHCP" or "BOOTP" is selected, the IP address is obtained automatically as "DHCP client" or "BOOTP client". At this time, it is necessary that the DHCP server/BOOTP server must be in the environment allowing the network communication. IP Address, Subnet Mask, and Gateway Address fields will be displayed "-.-.-", when the IP Address Configuration Method is set to DHCP or BOOTP and failed to get the figures from the DHCP server, the computer cannot be connected to the projector. If the projector fails to obtain IP address from BOOTP server, the existing IP address will be assigned.
IP Address	Set the IP address in the environment you wish to use. If "IP Configuration Method" is set to "DHCP" or "BOOTP", this setting is not needed.
Subnet Mask	Set the Subnet mask in the environment you wish to use. If "IP Configuration Method" is set to "DHCP" or "BOOTP", this setting may become unnecessary depending on the settings of "DHCP Server" and "BOOTP Server".
Gateway Address	Set the gateway address in the environment you wish to use. If "IP Configuration Method" is set at "DHCP" or "BOOTP", this setting may become unnecessary depending on the settings of "DHCP Server" and "BOOTP Server". If any segment beyond the router is not used, the gateway address can be remained "255.255.255.255".
Wireless Mode*	Select the Communication mode 802.11b or 802.11g
Network Type*	Select either "Infrastructure" or "AdHoc".
SSID*	Set the SSID/ESSID. (up to ASCII 32 characters) SSID/ESSID is case-sensitive. Even though all characters projected in Wired/Wireless information are uppercase, it is necessary to distinguish between upper case and lower case characters.
APPLY button	Click the APPLY button to update. The screen to restart the projector will be displayed.
REFRESH button	Update and show the adjusted data.
RESTORE Factory Default Settings button	Restore the settings to the values at the factory.

* Not displayed at Wired LAN setting.

Advanced Setup

(Click "+" mark to display the subitems.)

TCP / IP

TCP/IP related items can be configured on this screen.

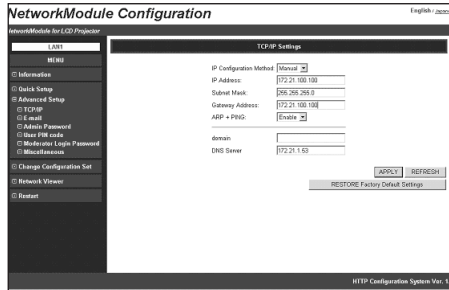

Parameter	Description
IP Configuration Method	A desired IP address setup method is selected from "Manual", "DHCP", and "BOOTP". If "DHCP" or "BOOTP" is selected, the IP address is obtained automatically as "DHCP client" or "BOOTP client". At this time, it is necessary that the DHCP server/BOOTP server must be in the environment allowing the network communication. IP Address, Subnet Mask, and Gateway Address fields will be displayed "-.-.-", when the IP Address Configuration Method is set to DHCP or BOOTP and failed to get the figures from the DHCP server, the computer cannot be connected to the projector. If the projector fails to obtain IP address from BOOTP server, the existing IP address will be assigned.
IP Address	Set the IP address in the environment you wish to use. If "IP configuration Method" is set to "DHCP" or "BOOTP", this setting is not needed.
Subnet Mask	Set the Subnet mask in the environment you wish to use. If "IP Configuration Method" is set to "DHCP" or "BOOTP", this setting may become unnecessary depending on the settings of "DHCP Server" and "BOOTP Server".
Gateway Address	Set the gateway address in the environment you wish to use. If "IP Configuration Method" is set at "DHCP" or "BOOTP", this setting may become unnecessary depending on the settings of "DHCP Server" and "BOOTP Server". If any segment beyond the router is not used, the gateway address can be remained "255.255.255.255".
ARP+PING	Select "Enable" or "Disable" the IP address setup using "arp" and "ping" (Refer to P96 for details)
Domain	Enter the domain name where the projector belongs to. (up to ASCII 254 characters)
DNS Server.....	Enter the address of the DNS server.
APPLY button.....	Click the APPLY button to update. The screen to restart the projector will be displayed.
REFRESH button	Update and show the adjusted data.
RESTORE Factory Default Settings button	Restore the settings to the values at the factory.

Wireless Setting

Wireless related items can be configured on this screen.

This screen will not be displayed at Wired LAN setting.

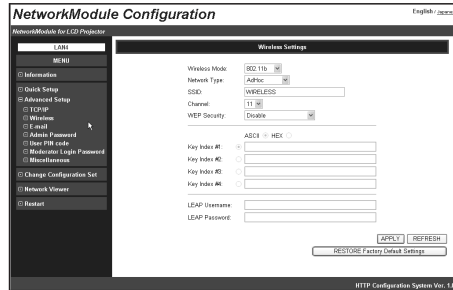

Parameter	Description
Wireless Mode	Select the Communication standard 802.11b or 802.11b.g
Network Type	Select either "Infrastructure" or "AdHoc".
SSID*	Set the SSID/ESSID. (up to ASCII 32 characters) SSID/ESSID is case-sensitive. Even though all characters on the Wireless information is uppercase, it is necessary to distinguish between upper case and lower case characters.
Channel.....	If you use the projector in 802.11AdHoc mode, select the channel, from 1 to 11.
WEP Security	Select "Enable" or "Disable" the WEP(encryption). When using WEP, select any of following items corresponding to this WEP; "Enable 40-bit", "Enable 104-bit", "Enable 128-bit" and "Enable (802.1x"LEAP")" When enabling WEP (Encryption), the image transfer speed may become slower.
WEP Key#1- Key#4	Set WEP key in the hexadecimal notation (0 to F). 5 bytes are set for 40-bit WEP, 13 bytes are set for 104-bit, and 16 bytes are set for 128-bit WEP. Four WEP keys can be set, however, the only one with check on its radio button is in effect. Both of the number and value of the WEP key in effect must be same as those of your computer and the access point. Depending on computers and access points, you may be allowed to select only one WEP key. In this case, use WEP key 1.
LEAP Username / Password	When selecting 802.1 x "LEAP" in WEP security, enter the user name and the password. Enter with ASCII 64-byte capital characters and one-byte characters. Consult your system administrator about the user name and the password.
APPLY button	Click the APPLY button to update. The screen to restart the projector will be displayed.
REFRESH button	Update and show the adjusted data.
RESTORE Factory Default Settings button	Restore the settings to the values at the factory.

6. Configurations with Browser

E-mail

The projector has a function to send e-mails to inform its operating condition to the administrators or users. This function can not be used for Wireless AdHoc mode. This function is available only for Wired or Wireless LAN infrastructure mode.

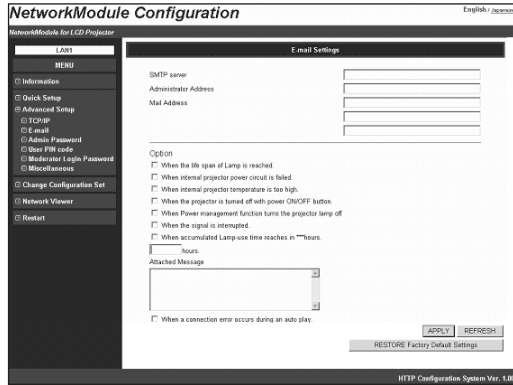

Parameter	Description
SMTP Server	Enter the address of SMTP server. (up to ASCII254 characters)
Administrator Address	Enter the E-mail address of administrator. (up to ASCII254 characters)
Mail Address	Enter E-mail addresses of users. (up to ASCII254 characters)
Option.....	When the checked item has occurred, the projector sends alert messages.
Time	Set the time of "Accumulated Lamp-use time reaches in ***hours".
Attached Message	Attach the message to the e-mail of "Accumulated Lamp-use time reaches in ***hours". (up to ASCII220 characters)
APPLY button.....	Click the APPLY button to update. The screen to restart the projector will be displayed.
REFRESH button	Update and show the adjusted data.
RESTORE Factory Default Settings button	Restore the settings to the values at the factory.

Admin Password

Set the Admin Password to prevent unauthorized person from changing the settings of the projector. At the factory settings, the Admin Password is not set.

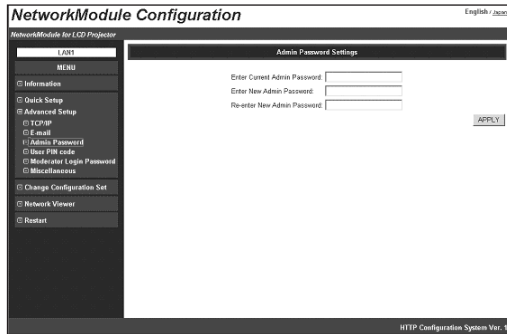

Parameter	Description
Enter Current Admin Password.....	Enter the currently set admin password. The password you have entered is displayed as "●●●●●●●●". (up to ASCII32 characters)
Enter New Admin Password	Enter a new admin password you wish to set. The password you have entered is displayed as "●●●●●●●●". (up to ASCII32 characters)
Re-enter New Admin Password.....	Re-enter the new admin password you wish to set. The password you have entered is displayed as "●●●●●●●●". (up to ASCII32 characters)
APPLY button	Click the APPLY button to update. The screen to restart the projector will be displayed.

If you set the admin password for the first time, do not enter any password in the "Enter Current Admin Password" field. Enter a password in "Enter New Admin Password" and "Re-enter New Admin Password" fields.

When you change the settings next time, the password will be required to enter. Leave the "User name" field blank and enter the password you set.

* The password set here is also used as PJ link password.



6. Configurations with Browser

User PIN code

With this screen, you can set the User PIN code to transfer the image to the projector and to activate PJ Controller.

You can set different PIN code as you set for Admin Password. (p49)

When you reset the User PIN code, you do not need to enter the current PIN code.

At the factory setting, the User PIN code is not set.

If you do not need to set a PIN code, enter "0000".

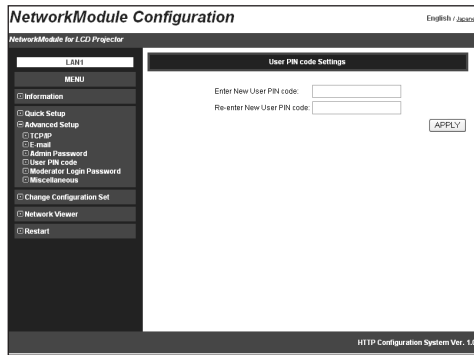

Parameter	Description
Enter New User PIN code.....	Enter a new PIN code you wish to set. The PIN code you have entered is displayed as "●●●●". (four-digit numbers)
Re-enter New User PIN code.....	Re-enter the new PIN code you wish to set. The PIN code you have entered is displayed as "●●●●". (four-digit numbers)
APPLY button.....	Click the APPLY button to update. The screen to restart the projector will be displayed.

Moderator Login Password

To use the Moderator function, you need to set the Moderator Login password here. For operating the Moderator function, a Moderator Login password is required on this screen. When resetting the Moderator Login password, you do not need to enter the current Moderator Login password. Default setting is blank. If you do not want to set a password, leave here blank.

* First, you need to set the admin password or you cannot set the moderator login password.

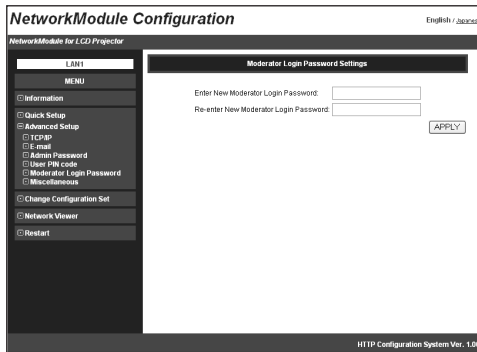

Parameter	Description
Enter new Moderator Login password.....	Enter new Moderator Login password. After inputting, the figure will be displayed as "●●●●". The password consists of four -digit number.
Re-enter new Moderator Login password ...	Reenter new Moderator Login password. After inputting, the figure will be displayed as "●●●●".
APPLY button	Click the APPLY button to update. The confirmation message about updating the Moderator Login password will be displayed.

Miscellaneous

You can set the name to the projector. The set name will be displayed on the Network Projector List of the application operating screen.

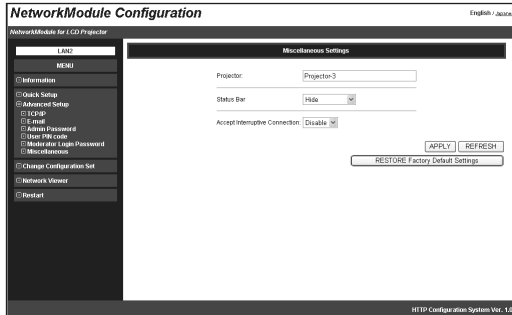

Parameter	Description
Projector.....	Name a projector to distinguish it from other projectors. (up to 32 characters). The name set here will be displayed on the Network Projector List.
Status Bar	Select "Expand view" or "Hide" the Status bar on the network connection standby screen. When selecting "Hide", the Status bar on the network standby screen will be disappeared. Refer to "3. Names and Functions of the Operation Screen" → "Network Connection Standby Display". (p20)
Accept Interruptive Connection	Enable or Disable the interruptive connection to the projector which is connected to other computer when you send images using projector. (See "7. Project the Image via the networks" (p56) for further detail.)
APPLY button.....	Click the APPLY button to update. The screen to restart the projector will be displayed.
REFRESH button	Cancel the new settings.
RESTORE Factory Default Settings button	Restore the settings to the values at the factory.

Change Configuration Set

Select a LAN settings from LAN1-LAN3, Off, LAN4, LAN5, and SIMPLE. With this screen, you can also confirm some settings (Projector name, IP Configuration Method, IP Address, Wireless Mode, Network Type, Channel, SSID, WEP Security). Depending on Wireless or Wired input, setting items will be varied.

Wireless LAN set menu

The screenshot shows the 'Change Configuration Set' screen for a Wireless LAN configuration. The interface includes a left-hand menu with options like Information, Quick Setup, Advanced Setup, TCP/IP, Wireless, Email, Admin Password, User PIN code, and Miscellaneous. The main area displays the following settings:

Change Configuration Set			
Projector	<input checked="" type="radio"/> LAN4	<input type="radio"/> LAN5	<input type="radio"/> Simple
Projector	Projector-1		
IP Configuration Method	Manual	DHCP	Manual
IP Address	192.254.100.100	172.21.95.208	192.254.53.0
Wireless Mode	802.11b	802.11g	802.11b
Network Type	Ad-hoc	Infrastructure	Ad-hoc
Channel	11	11	11
SSID	WIRELESS	ANY	WIRELESS
WEP Security	Disable	Disable	Disable

Buttons for 'APPLY' and 'REFRESH' are located at the bottom right of the configuration area.

Wired LAN set menu

The screenshot shows the 'Change Configuration Set' screen for a Wired LAN configuration. The interface is similar to the wireless version but with different options. The main area displays the following settings:

Change Configuration Set			
Projector	<input checked="" type="radio"/> LAN1	<input type="radio"/> LAN2	<input type="radio"/> LAN3
Projector	Projector-1		
IP Configuration Method	Manual	DHCP	Manual
IP Address	172.21.95.202	172.21.95.202	192.168.100.100

Buttons for 'APPLY' and 'REFRESH' are located at the bottom right of the configuration area.

Parameter	Description
LAN1-5, SIMPLE*	Select a LAN setting from LAN1-3, LAN4, LAN5 and SIMPLE.
APPLY button	Click the APPLY button to update. The screen to restart the projector will be displayed.
REFRESH button	Cancel the new settings.

* LAN4, LAN 5 and SIMPLE will be displayed when USB Wireless LAN Adapter is inserted.

Restart

You can restart the projector on this screen.

To enable the new settings, the projector has to be restarted. Click "RESTART".

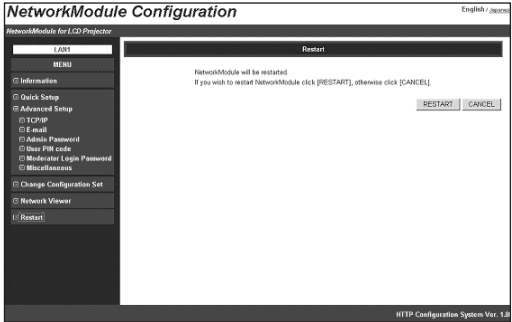

Parameter	Description
RESTART button	Click this button when you restart the projector after completing the settings.
CANCEL button	Cancel to restart the projector.

7. Project the Image via the Networks

Project the image on the computer screen by operating the projector which is connected to the networks.

7. Project the Image via the Networks

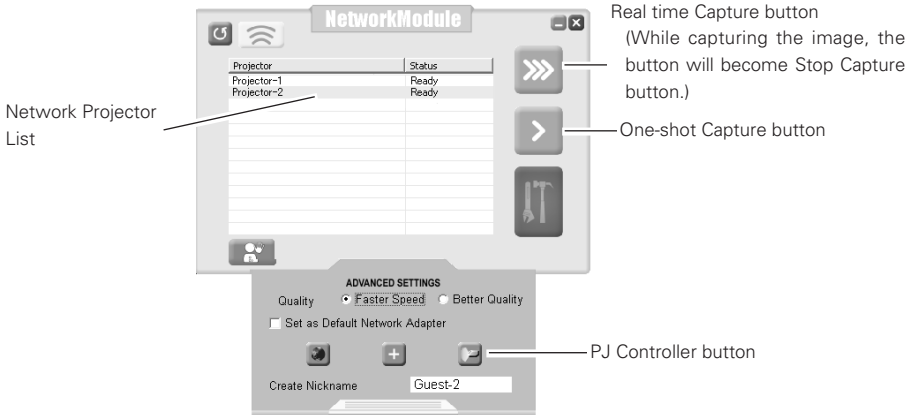

1. Activate NetworkModule Client (Participants) or NetworkModule Moderator (Moderator).
2. Adjust the projector input to the selected network (Wired or Wireless) with the PJ Controller. When operating multiple projectors, adjust each projector independently. Refer to "10. How to Use the PJ Controller". (p73-90)
3. Select a projector from the Network Projector List with a mouse cursor. When selecting multiple projectors at the same time, press the [Ctrl] key and select projectors with the mouse cursor. Selected projector will be blue. You can operate up to 5 projectors at the same time.
4. Click the Real time Capture button to project the computer image in real time.
 - * If the projector has already been being used, "In-use" message will appear on the Network Projector List. When the "Accept Interruptive Connection" setting is "Enable", you can use the projector even if it has "In-use" message. When the setting is "Disable", you cannot use the projector. Refer to "6. Configurations with Browser" → "Advanced Setup" → "Miscellaneous" (p52)

On the Real time Capture screen, the destination projector will be displayed in blue or black. When Real time capturing has been done, the Real time Capture button will become the Stop Capture button.

Click the One-shot Capture button to project a copied still picture of the computer screen. The quality or transmission speed of the projected picture can be set through Advanced settings. Click the Advanced settings button to display the menu. Select "Quick" or "Clear" with the check button.

When selecting "Quick", the image transmission speed will be quicker but the image quality will be lower. When selecting "Clear", the image quality will be better but the transmission speed will be slower.

When the User PIN code has been set, User PIN code screen will appear after clicking the Capture buttons. If multiple projectors have different PIN codes, you need to enter PIN codes for every projector. To set the User PIN code, refer to "4.Wired LAN setting" → "Set the User PIN code" (p30), "6. Configurations with Browser" → "Advanced Setup" → "User PIN code" (p50).

The same procedure will be required when operating via Moderator screen (NetworkModule Moderator). While projecting the image in real time, the projector cannot be operated via PJ Controller or browser.

* The projector cannot be connected to via the networks while using the viewer.

8. Use the Moderator Function

With Moderator function, the moderator can project the participants' computer screen through the projector in meetings or in classes.

8. Use the Moderator Function

Moderator Function

This function is useful for a moderator or a teacher to conduct a meeting or a class, where all the participants including the moderator (teacher) are assigned a computer, to project images from each participant's computer. A moderator (teacher) has the right to decide which computer image to project. One moderator (teacher) can conduct up to 50 computers. This function enables you to project the participants' data directly in a short time and in real time without taking time to transfer the data to the computer connected to the projector. The image data will not be limited by the computer's application because the data transfer of each computer adopts the screen capturing system.

Names and terms used in this chapter have following meanings.

- ModeratorModerator or teacher
- Client.....Participant of meetings or the classes
- NetworkModule ModeratorThe application which the moderator uses
- NetworkModule Client.....The application which the participants use
- NetworkModuleThe projector which is connected to the networks

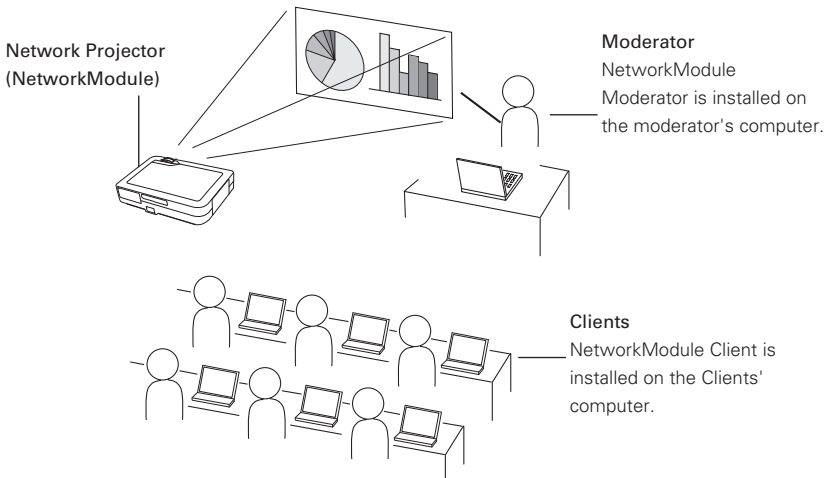

Preparation for Using the Moderator Function

First, follow the procedure in "2. Setup Procedure" → "Step 1-3" (p16) and confirm that the setting status is set as written below.

- Client application (NetworkModule Client) is installed on each client's (except for the moderator) computer and each client's computer image can be projected.
- Moderator application (NetworkModule Moderator) is installed on the moderator's computer and moderator's computer image can be projected.

Preparation Procedure for Using the Moderator Function

1. Configure the Moderator Login password in the projector to put the projector under moderator's control. (p51)
2. Register a moderator in the projector with the moderator screen. Set the Session password at this step. After the registration, only the moderator can control the projector and clients cannot operate.
3. Each client registers to join the moderator's group.

Now, Moderator function is set. The moderator and the clients can start the meeting with Moderator function.

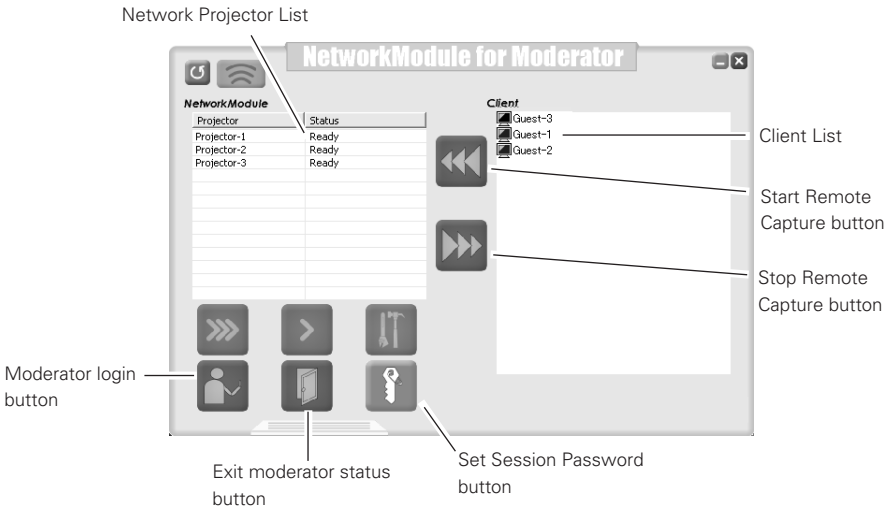

Setting the Moderator Function

.....

* See p62 for Easy Settings.

1. Turn on the Moderator's computer and activate the moderator's application.
Turn on the each client's computer and activate each of the applications.

Registration of the Moderator

2. The moderator sets the Moderator Login password to the projector. When operating multiple projectors, set passwords to all the projectors. It is preferable to set the same password to all the projectors.
Configure the setting with the browser. Refer to "6. Configurations with Browser" → "Advanced Setup" → "Moderator Login Password". (p51)
3. Register the moderator to each projector through the moderator screen. Select the projector on the screen (The selected projector will be blue.) and click the Moderator login button.
4. "Set Session Password" screen will appear.
Enter the same password (less than 16 one-byte characters) into the two input boxes and click "OK".



5. Moderator login password confirmation screen will appear.
Enter the password set in step 2 and click "OK". The projector has been put under the moderator's control. The projector will be pink in the Network Projector List.
Repeat step 3, 4, 5 and put each projector under the moderator's control. After completing the setting, the registered projector can only connect to the computers which belong to the session group.



Registration of the Clients (Participants)

6. Select the projector (Selected projector will be blue.) in the group from the client screen. (Moderator's projector will be pink.) Click the Join the moderated session button.

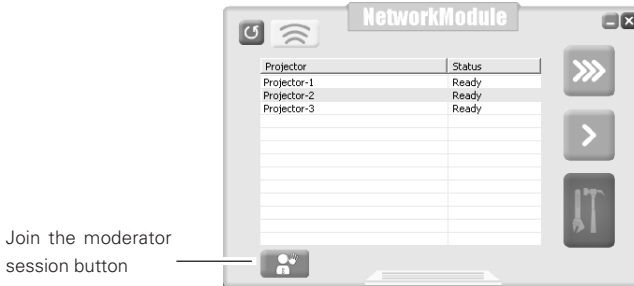

7. Set session password screen will appear. Enter the password registered by a moderator (Being registered at step 4)



8. Click "OK". The client screen will disappear and the projector icon will be displayed in the task tray of the computer. After the step, the client's (participant's) computer name will be put under the moderator's control. When joining the session, the client's computer (or the nickname) will be displayed in the moderator's client list screen.

To quit the session, right-click the projector icon on the computer task bar and select "Exit from the moderated session" from the menu. The client screen will appear and the client has left the group.

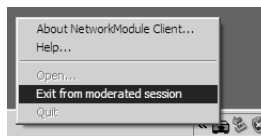

- * Set session password screen will be displayed by clicking the Set session password button. Enter new password, then it will be a new password. If the password has changed while the session is in progress, the clients who are participating the session will not be excluded from the session.
- * The projector displayed in red on the client's screen means it is for moderator. Operation cannot be done through the client screen.

All the preparation settings have been done for moderator function. Follow the instructions of "How to Use Moderator Function" on the next page for the operation.

Unregister from Moderator Status

1. Select a projector which is registered as a moderator from the moderator screen.
2. Click the Exit moderator status button. Selected projector will be unregistered as a moderator.
When there are multiple projectors to unregister, repeat the procedure for each projector.
The moderator cannot unregister while an image is transferring to the projector. First, stop transferring the image and then unregister.
After unregistering, client's name will be disappear from the client list on the moderator screen.
 - * Even after the moderator is unregistered, the function will not finish automatically in the clients computers. Each client needs operation to quit the session.
 - * After terminating the moderator's application, all the clients joined in the session will be unregistered.

How to Use the Moderator Function

The moderator function is to project each client's (participant's) images on the computer with the moderator's operation. Clients themselves cannot operate to project the image directly.

Project the Client's Images

1. Select the client to display its computer image from the client list with the computer mouse. (Selected client will be blue.)
2. Select the projector to project the image with the computer mouse. (Selected projector will be blue.) When projecting through multiple projectors, select the projectors with the computer mouse by holding the [Ctrl] key.
3. Click the Capture button. Selected client's image will be projected from the projector in real time.

Stop Projecting the Client's Images

Select the client to stop being projected the image from the client list, and click the Stop Remote Capture button. The capturing will stop.

- * The client whose image is projecting cannot exit from the session. Once its image stops being projected, the client can exit.
- * If the moderator's image is projected by the One-shot Capture button or the Real time Capture button, the client's image which is being projected will be cancelled.

Easy Settings for Moderator Function (Set the Moderator Login password)

You do not have to set each Moderator Login password for every equipment if following the instructions. The password is to control the projector and clients' computers thoroughly. With following procedures, you can omit inputting the password to use the moderator function more simply.

1. Skip step 2 of "Set the Moderator Function". (p60) Do not set the password.
2. Enter the Session password in step 4.
When the other group is not using the function, you can also skip the password. Click "OK" without inputting each box (without password). When the other group is using the function, enter the password here to prevent the session from interfering.
3. The confirmation screen in step 5 will not appear.
4. Each client (participants) will joins the session in step 6. Inputting the password will not be required.
When setting the Moderator Login password in step 2, you need to enter the password here.

9. How to Use Network Viewer

Project images on a FTP server, which is on the same LAN with the projector, through the projector by operating a projector or a computer.

First, check if the projector and the computer are connected to the networks correctly with Wired or Wireless, to project the image properly.

9. How to Use Network Viewer

The Mechanism of Network Viewer and the Flow of the Signal

Network Viewer is to project an image stored on a FTP server which is on the same LAN as a computer, through the projector by operating a computer or a projector. The flow of the signal for each communication mode is shown below.

■ Wireless LAN Infrastructure Communication Mode

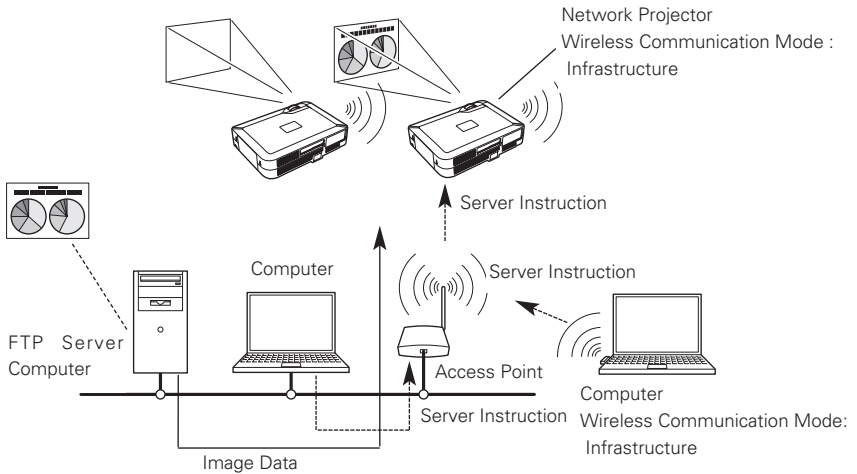

■ Wireless LAN AdHoc Communication Mode

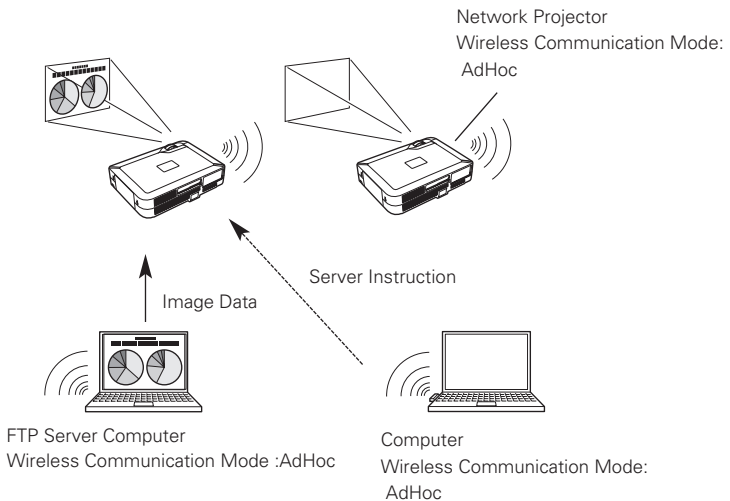

■ Wired LAN Communication Mode

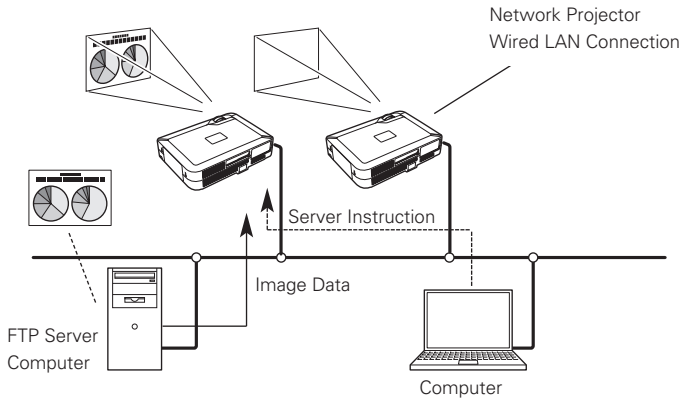

Operation

Procedures for projecting the images on the FTP server are as follows.

1. Information about the FTP server, which provides images, is sent from the computer to the projector and the information will be held.
2. The computer issues an instruction to project the image, then the projector will follow the instruction and read the image data each time to project.
The projector can also instruct to project images on FTP server. In this case, operation written in step 1 is required in advance.

Functional Conditions of FTP Server Which Provides Images

- * FTP Service can be available with Windows NT4.0, Windows2000 Professional, or Windows XP Professional.
- * FTP Server has an account which has full account right or allows an anonymous account.

Projecting the Image

Operation can be made with any of 1) PJ Controller, 2) Browser, or 3) Projector.

When operating with the projector, first, set the FTP server which provides images with 1) PJ Controller or 2) Browser.

Operate as follows.

1) Operating with the PJ Controller

1. Select the projector input (Wired /Wireless).

Select "Wireless" for Wireless LAN and "Wired" for Wired LAN for the input source of the projector. Activate "NetworkModule Client" or "NetworkModule Moderator".

Detected projector names and IP addresses will be displayed.

2. Specify the projector to display the image.

Only one projector can be selected.

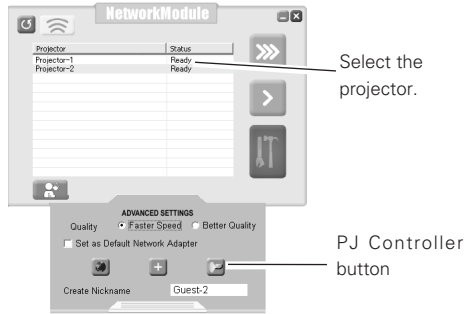

3. Click the PJ Controller button to display the PJ Controller screen. First, make "Initial Setting" from the main menu. Refer to "10. How to Use PJ Control" → "Initial Settings". (p75)

4. Select Network Viewer from the Main Menu. Operation window (next page) will be displayed.

[Network Viewer]

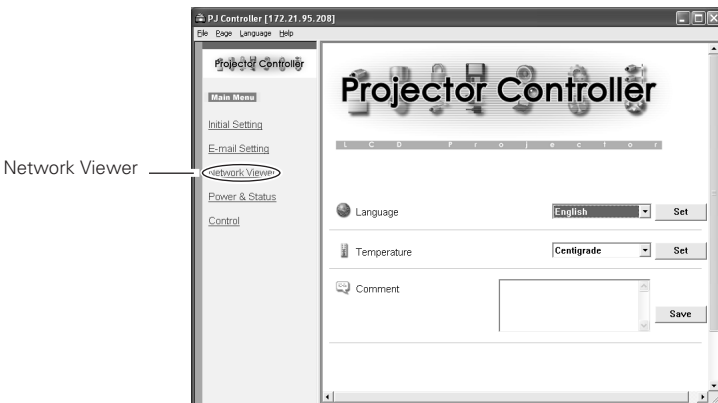

5. Specify the FTP server to provide image data
 - Host Name.... Enter IP address of the server.
 - Folder Path.... Specify the directory where image data are stored. When the image data is in the root directory, just "/" will be displayed. When the image data is in a specified directory, put slashes "/" between directories such as /test/data etc.
 - User IDEnter login ID access to the server.*
 - PasswordEnter login password access to the server.*
 - *If both the User ID and password are anonymous, enter "anonymous".

6. Click Set button
 - Click Set button to set up the server information on the specified projector.
 - The configured server information can be stored even if you unplug the projector .

7. Select Play Mode and display the image
 - Play ModeAuto (Infinite Loop) (Keeps playing images repeatedly)
 - Auto (Plays or pauses all the images according to the Auto Play Setting mode)
 - Manual (Plays images manually)
 - Auto Play Settings..Sec. (Sets time of playing back a image.)
 - Times (Select number of times of play back images.)
 - Start.....Start playing back images.
 - StopStop playing back images.
 - PauseSuspend playing back images in Auto Play mode.
 - ReturnReturn to the previous page manually in Manual mode
 - NextGo to next page manually in Manual mode.

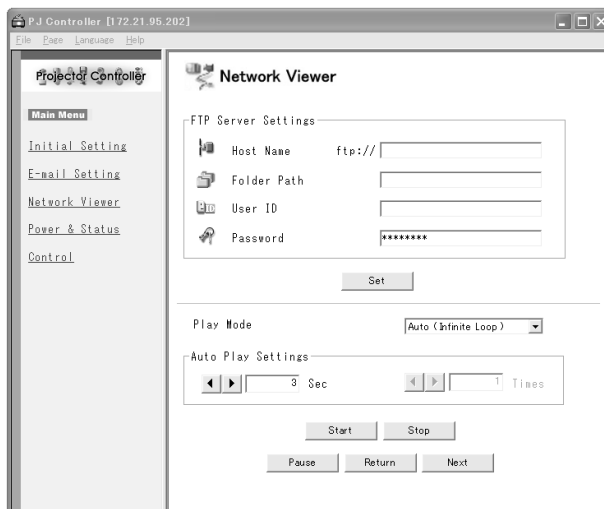

2) Operating with the Browser

1. Select "Wireless" for Wireless LAN and "Wired" for Wired LAN from the input menu of the projector.
Activate " NetworkModule Client" or "NetworkModule Moderator".
Operating directly from the browser is also possible. In this case, enter the projector IP address directly into browser's address bar.

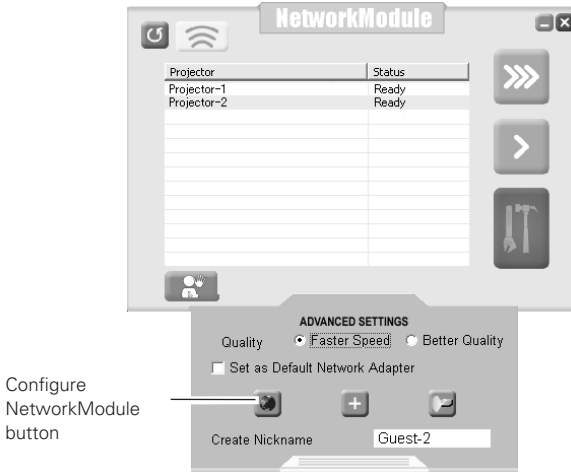

2. Specify the projector to display the image
Only one projector can be selected.
3. Click "NetworkModule Setting" button (See page 39)
The browser will start and projector setting screen will appear.
Select Network Viewer from the MENU.
Network viewer operation (next page) will appear.

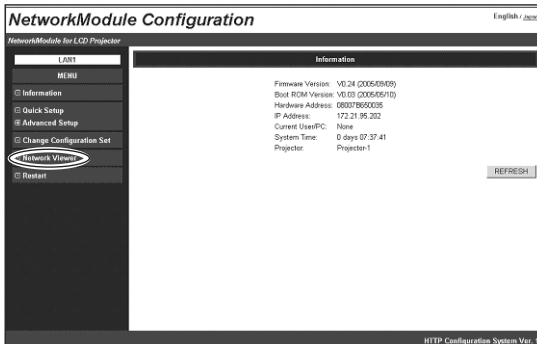

4. Specify the FTP server to provide image data
 - Host Name.....Enter the IP address of the server.
 - Folder Path.....Specify the directory where image data are stored. When the image data is in the root directory, just "/" is displayed. When the image data is in a specified directory, put slashes"/" between directories such as /test/data etc.
 - User IDEnter the login ID access to the server.*
 - PasswordEnter the login password access to the server.*

*If both the User ID and password are anonymous, enter "anonymous".

5. Click APPLY button
 - Click APPLY button to set up the server information on the specified projector.
 - The configured server information can be stored even if you unplug the projector .

6. Select Play Mode and display the image
 - Play ModeAuto (Infinite Loop) (Keeps playing images repeatedly)
 - Auto (Plays or pauses all the images according to the Auto Play Setting mode)
 - Manual (Plays images manually)
 - Auto Play Setting...Sec. (Sets time of playing back a image.)
 - Times (Select number of times of play back images.)
 - Start.....Start playing back images.
 - StopStop playing back images.
 - PauseSuspend playing back images in Auto Play mode.
 - ReturnReturn to the previous page manually in Manual mode.
 - NextGo to next page manually in Manual mode.
 - REFRESHUpdate and show the adjusted data.
 - RESTORE Factory Default Settings
 -Restore the factory default settings of Network Viewer.
 - (All the values will return to the factory default settings.)

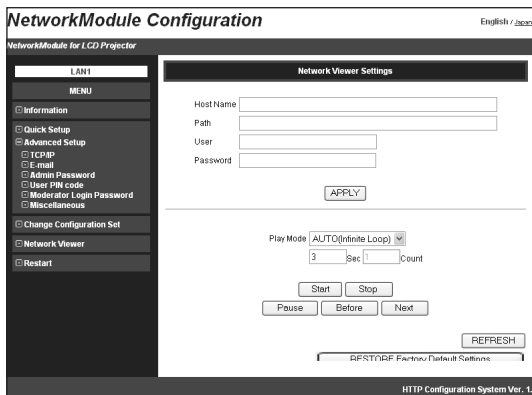

3) Operating with the projector

Before operating the Network Viewer from the projector, the FTP server needs to be configured by PJ Controller or browser in advance.

Regarding the configuration of the FTP server, refer to "1) Operating with PJ Controller" (p66, 67) or "2) Operating with browser". (p68, 69)

1. Configure the FTP server which provides image data, referring to "Operating with PJ Controller" or "Operating with browser".
2. Select "Wireless" for Wireless LAN and "Wired" for Wired LAN for the input source of the projector.
3. Select "Wireless Viewer" when using Wireless LAN or "Wired Viewer" when using Wired LAN from the projector menu. The Viewer Setting screen will appear.

[Wired LAN]

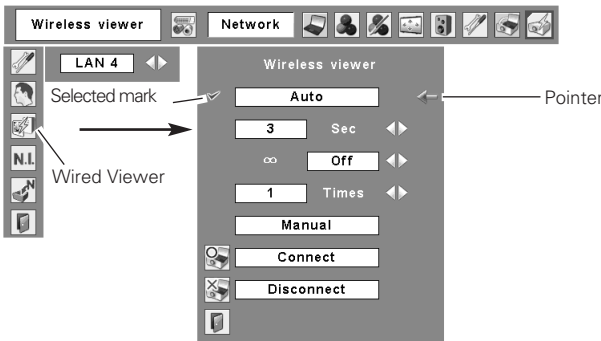

[Wireless LAN]

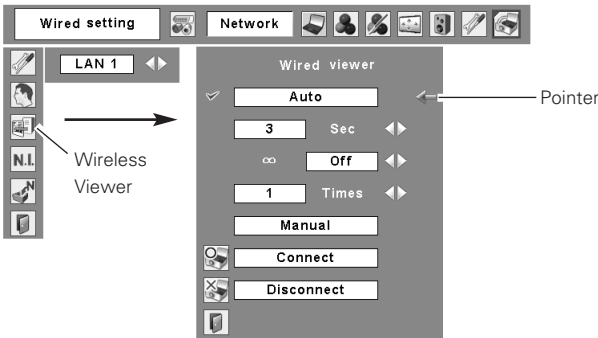

4. Select, execute, and stop the mode of image replay.

Move the red arrow pointer to the item you wish to choose.

Using Point buttons and SELECT button of the projector, configure or execute each item.

AutoPlay images and stop playing according to following configurations.

SecondSet timing to switch images in Auto play mode. (3-240 sec.)

∞Set "On" to make the projector keep playing images repeatedly.

TimesSpecify the number of repeating times of auto play. (Maximum 255 times)

ManualSwitch images manually.

Press the Point ▲ button on the projector (or the remote control) to show the next image and the Point ▼ button to show the previous image.

Connect to the FTP server

.....Move the red arrow pointer to "Connect" and press SELECT button on the projector (or the remote control) to connect the projector to the FTP server. Then the projector starts playing the images in the FTP server.

Disconnect from the FTP server

.....Move the red arrow pointer to "Disconnect" and press SELECT button on the projector (or the remote control) to disconnect the projector from the FTP server.

10. How to Use the PJ Controller

Control the projector operation on the network.

PJ Controller works for;

- Operating the projector
- Operating the Network viewer
- Controlling the projector
 - Monitor the operation status of the projector in real time.
 - Send an e-mail to the administrator about operation status of the projector.
- Operating multiple projectors simultaneously.
(Multi Control)

10. How to Use the PJ Controller

How to Operate

This operation requires that the projector is set correctly on the network and the image in the computer is properly displayed from the projector with "NetworkModule Client" or "NetworkModule Moderator" applications on the computer.

Activate the PJ Controller.

1. Activate the "NetworkModule Client" or " NetworkModule Moderator".
2. Select the Advanced settings screen.
3. Select a projector from the Network Projector List. (Selected Projector name will be blue.)
You can select and operate one projector only. Multiple projectors cannot be operated. If you select and execute multiple projectors, another function screen (Multi Control Screen. See p89-90.) will appear.
4. Click the PJ Controller button then the PJ Controller screen will appear.
Left side of the screen is the Operation Item Selection Screen.
Right side of the screen is the Screen for Adjustment.
First, Initial Setting Menu will appear. Before using PJ Controller, set the items on this screen.
5. To terminate PJ Controller, select "Exit" from "File" in the tool menu.

* The projector cannot be connected to via the networks while using the viewer.

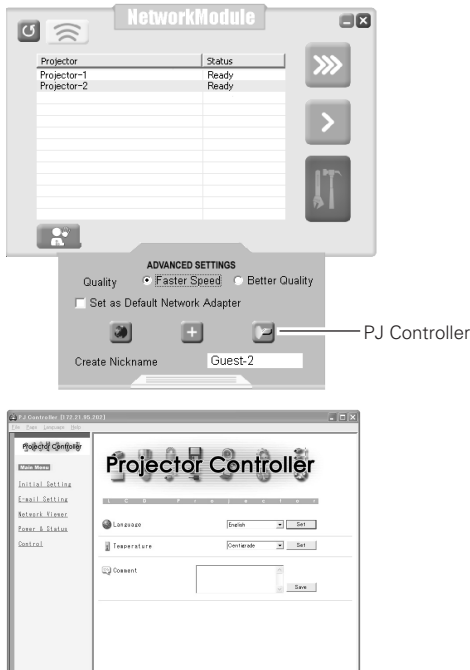

Initial Settings

Before using the PJ Controller function, initial setting is required.

1. Select Initial Setting from the main menu and configure each item.



Parameter	Description
Language	Select a desired language from the pull-down menu, and click "Set".
Temperature	Set the unit of temperature displayed on the control screen of the projector. Select "Centigrade" or "Fahrenheit" from the pull-down menu and click "Set".
Comment	You can store any comments regarding the initial settings. To save the comments you entered, click "Save".

E-mail Setting

The projector has a function to send an e-mail to inform its operating condition to the administrator or users. Select E-mail Setting from the main menu and configure each item as follows:

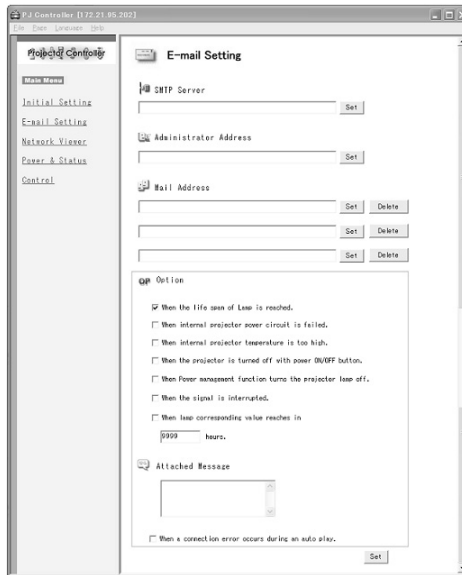

1. Registering E-mail Address

Parameter	Description
SMTP Server	Enter the address of SMTP server and click "Set".
Administrator Address	Enter the E-mail address of administrator and click "Set".
Mail Address	Enter E-mail addresses of users and click "Set". To delete the E-mail address, click "Delete".
Option.....	When the checked item has occurred, the projector sends alert messages.

- * The SMTP server is a server for sending E-mail. Please contact your network administrator to have this SMTP server address.
 - * To use the E-mail function, the DNS address must be set correctly.(Refer to "6. Configurations with Browser" → "Advanced Setup"→ "TCP/IP" (p46).)
- You cannot use this E-mail function if the SMTP server is not available in your network environment. If the SMTP server is located in your LAN (Local Area Network), the address set to SMTP server should be specified the in SMTP server located in your LAN. The server located outside of your LAN may not be available for security reason. For further information, please contact your network administrator.

2. Check Option items

Check the conditions where you would choose the projector to send an alert message.
Regarding the alert message, see samples below.

3. Enter the message to attach the E-mail.

The message typed here will be attached to the alert message.

Samples of Alert Message

- * When the internal temperature is too high

TITLE: Message from projector
Projector Model Name: XX100
TCP/IP: 192.168.0.111 Projector Name:

It sends you following message.

- * The Projector lamp is turned off, because internal projector temperature is too high.
Wait for the Temperature Warning Indicator to be turned off, and then turn the Projector on again.
If the Indicator continues flashing, check the air filter for dust accumulation.

"A" 21.5degrees centigrade"B" -13.7degrees centigrade"C" 51.6degrees centigrade
Temperature of Sensor B is too high.
Temperature of Sensor C is too high.

- * The Network projector let users know the information which thermal sensor "A", "B" or "C" inside the projector detected the abnormal temperature risen and so the projector was turned off. Please refer to the item "Check the status of projector" for the location of the sensors "A", "B" and "C", and temperature (p.79). Also see the owner's manual of the projector for further details.

- * When the internal power is failed

TITLE: Message from projector
Projector Model Name: XX100
TCP/IP: 192.168.0.111 Projector Name:

It sends you the following message.

- * The Projector lamp is turned off, because projector power circuit is failed.
Unplug this projector from AC outlet and ask for servicing to qualified service personnel.

- * The Projector lamp was turned off, because the projector power is failed.
Unplug the projector from AC outlet and ask servicing to a qualified service personnel

- * When the life of the lamp has been expired

TITLE: Message from projector
Projector Model Name: XX100
TCP/IP: 192.168.0.111 Projector Name:

It sends you the following message:

- * The life span of lamp is reached. Lamp replacement is required.

- * Replace it with a new lamp immediately and reset the lamp counter. If the projector is used without resetting the lamp counter, the alert e-mail will be sent every time turning on the projector.

Power & Status

Click "Power & Status" on the main menu and configure each item.

1. Turning on/off the projector

Click Standby / ON buttons. When clicking the Standby button, the confirmation message will appear. Click OK to turn off the projector.

CAUTION: Projector cannot be turned on for approximately 90 seconds after it being turned off. When the display of "Power Status" changes from " On cooling down" to " On", click ON to turn on the projector.

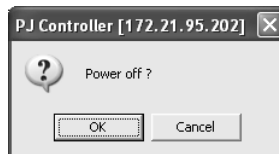
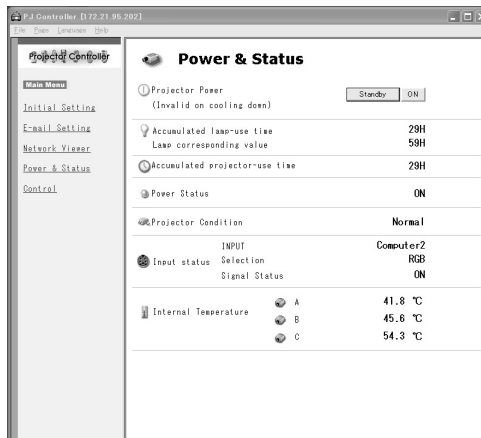

Caution about turning on / off the projector via the networks

When you wish to turn on / off the projector via the networks, preset the projector as follows:

1. Select "Setting" from the Projector menu.
2. Select "Standby mode" from the Setting menu and set it as "Normal".

If you set this function as Normal, the network part of the projector is constantly provided with power even if the projector is turned off. If you set this as Eco, then the network part will be turned off when you turn off the projector. Consequently, you cannot turn on / off the projector via the networks.

2. Check the status of the projector

The following items can be checked on the Power & Status screen.

Parameter	Description
Accumulated lamp-use time.....	Display the accumulated time of lamp use in hour increment.
Accumulated projector-use time	Display the accumulated time of projector use in hour increment.
Power Status	Display the status of the projector's lamp as follows: "On", "Off", "Standby", "Power Saver" "Mode / On cooling down", "Temperature Error / On cooling down", "On starting up", "On power management operating", "Temperature Error / Standby".
Projector Condition.....	Display the projector's condition as follows: "Normal", "Temperature Error", "Power Failure"
Input Status	Display the following input status
Input.....	Display the selected input mode.
Selection	Display the selected input source mode.
Signal Status	Display the signal status.
Internal Temperature.....	Display the detected internal temperature of the projector. The icons A, B and C stand for the thermal sensors inside the projector. If the internal temperature exceeds the certain point, each icon changes as below and let users know the error. Check the air filters and surrounding area of exhaust and intake vents of the projector.

Icon A, B and C are located as follows:
A: Ambient temperature of the projector
B: Ambient temperature of the panel
C: Ambient temperature of the lamp

* The ambient temperature of the projector may be shown a little higher than the actual temperature.

Control

When you select Control from the main menu, Control Menu will appear at the bottom of the screen. Using this menu, you can adjust or configure the projector.

Note: Control items displayed on this screen are varied depending on the input source or product model of the projector. So the figures shown in this section may be different from the actual screen displayed on your computer. For further details, refer to the owner's manual of your projector. This function is not available if the projector is turned off.

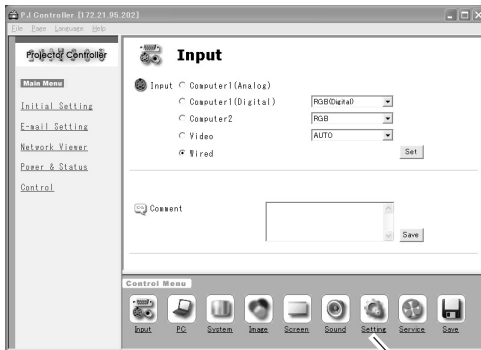

Input

Control Menu

On this screen, you can select an input source of the projector. Check the input terminal and select the signal mode from the pull-down menu. Click Set button to switch the input. You can save a note in Comment field. Click Save button to save the note.

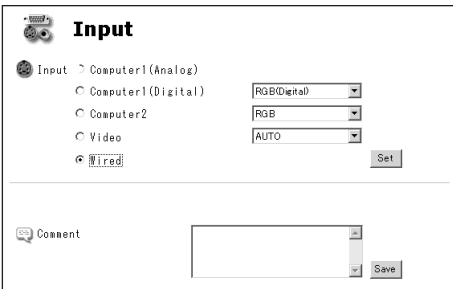

Parameter	Description
Wireless/.....	WiredSelect this input when using the Screen Capture or the Network Viewer function.
Computer 1 (Analog).....	Select the computer analog input.
Computer 1 (Digital).....	Select the input source from "RGB(Digital)" or "RGB(AV HDCP)".
Computer 2.....	Select the input source from "RGB", "Component", and "RGB (Scart)".
Video.....	Select the input source from "AUTO", "VIDEO", and "S-VIDEO".



PC adjustment

This feature optimizes the signal from the connected computer to display the screen.

* PC adjustment screen is displayed only when Computer1 (Analog) or Computer 2 (RGB) is selected for the input source.

The screenshot shows the 'PC Adjustment' interface. At the top, it displays 'Current Mode' as 'XGA1'. Below this is an 'Auto PC adjustment' section with a 'Start' button. The main area contains several adjustable parameters, each with a numerical value, a small input field, and left/right arrow buttons, followed by a 'Set' button. These parameters include: Fine sync (16), Total dots (1344), H Position (297), V Position (35), Clamp (1), Display Area H (1024), and Display Area V (768). There are also dropdown menus for 'Load Setting No.' and 'Save Setting No.', with a 'Mode free' button next to the latter. At the bottom, there is a 'Comment' text area with a 'Save' button.

Parameter	Description
Current Mode	Display computer mode
Auto PC adjustment.....	Executed by clicking Start button.
Fine sync	Click ◀▶ to adjust the value
Total dots	Click ◀▶ to adjust the number to fit your computer image.
H Position	Click ◀▶ to adjust the horizontal position.
V Position.....	Click ◀▶ to adjust the vertical position.
Clamp.....	Click ◀▶ to adjust the clamp level.
Display Area H	Click ◀▶ to decrease/increase the value to fit resolution of the image.
Display Area V	Click ◀▶ to decrease/increase the value to fit resolution of the image.
Load Setting No.	Load the preset settings(Mode 1-5)
Save Setting No.	You can save the settings of the PC adjustment. Select the mode number you wish to save and click "Set". * If you want to delete the content in the mode. Select the mode and click "Mode free".
Comment.....	You can save a note regarding the PC adjustment. Click "Save" to save the note.



SYSTEM Adjustment

On this screen, you can select the color system and scan mode for the video signal. This screen is displayed only when Video (Video/Component) is selected for the input source of the projector. Depending on the signal, the screen is varied as follows.

Component Input

Parameter	Description
System Adjustment	Select a scan mode of component signal.
AUTO	Automatically adjust to the scan mode of the input signal.

VIDEO/S-VIDEO Input

Parameter	Description
Color System Adjustment	Select a color system of Video/S-Video signal.
AUTO	Automatically adjust to the color system of the input signal.

NOTE: Items in System Adjustment are displayed only for video input (video/Component).



Image Adjustment

On this screen, you can adjust the image projected from the projector. Select an Image Adjustment Mode from the pull-down menu and click Set button. The items displayed on this screen is automatically changed according to the input signal. Click ◀▶ buttons to adjust the value. Every time you change the value, click Set button. If you click Reset button, all the adjusted values will be reset.

- * Some items may not be adjusted depending on the functions of your projector or input signal. In this case, "—" will be shown in the field of the item.

Parameter	Description
Image Adjustment Mode.....	Select from "Dynamic", "Standard", "Real**", "Cinema**", "Black Board", "Image 1 – 4", from the pull-down list. Image 1 - 4 can be set by users.
Original Mode	Displays the original mode.
Contrast	Click ◀▶ to adjust the image contrast.
Brightness	Click ◀▶ to adjust the image brightness.
Tint.....	Click ◀▶ to obtain a proper image.***
Color	Click ◀▶ to adjust the color intensity.
White Balance	
Color Temp.	Click ◀▶ to adjust the color temp level. (XLow, Low, Mid or High)
Red, Green, Blue	Click ◀▶ to adjust white balance of the image.
Gamma	Click ◀▶ to obtain a better balance of contrast.
Sharpness	Click ◀▶ to adjust the image sharpness.
Noise Reduction**	Set the Noise Reduction function.
Progressive**	Switch progressive mode : "Off", "L1"(motion picture), "L2"(still picture), Film
Comment.....	You can save a note regarding Image Adjustment. Click "Save" to save the note.
Store	You can save the settings of the Image Adjustment. Select the mode number you wish to save and click Set button. If you click "Reset", all the adjusted values will be reset.

* Items only for computer input.

** Items only for video input.

*** If the color system is PAL, SECAM, PAL-M or PAL-N, tint cannot be adjusted.



Screen

You can select a screen mode on this screen. The items displayed on this screen is automatically changed according to the input signal.

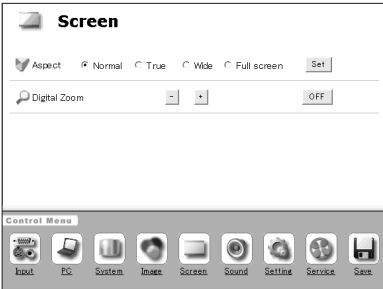

Parameter	Description
Aspect.....	Select "Norma", "Real*", "Wide", or "Full screen*".
Digital Zoom*	Click "+", or "-" button to enlarge or minimize the screen size. Click "OFF" to cancel this function.
* Items only for Wireless, Wired Computer1 (Analog) or Computer2 (RGB) input mode.	

* If "1080i", "1035i", or "720p" scan mode is selected from "System Adjustment" (Y, Pb/Cb, Pr/Cr input only) setting in "SYSTEM" screen, you cannot configure "Screen" settings.



Sound

On this screen, you can adjust the sound volume of the projector.

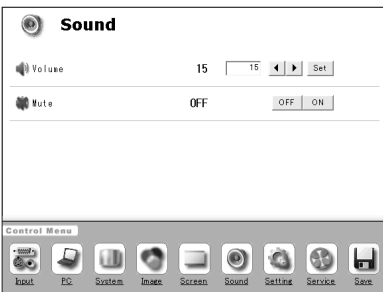

Parameter	Description
Volume	Click ◀▶ to adjust the volume.
Mute	Click "ON" to mute the sound and "OFF" to cancel this function.



Setting

On this screen, you can configure the projector. Refer to the next page for each item and description.

The items displayed on this screen are varied according to the functions provided to the projector.

Setting

Language	English	Set	
Auto Setup			
Auto PC Adjust	OFF	OFF	Set
Auto KeyStone	Auto	Auto	Set
Start			
<hr/>			
KeyStone			OFF
		<input type="checkbox"/> HighSpeed	
	Store	Reset	Store
<hr/>			
Blue Back	ON	OFF	ON
Display	ON	ON	Set
Logo Select	Default	Default	Set
Capture	Capture?		Yes
Ceiling	OFF	OFF	ON
Rear	OFF	OFF	ON
Terminal	Computer2	Computer2	Set
Standby Mode	Normal	Normal	Eco
No Show	OFF	OFF	ON
Freeze	OFF	OFF	ON
Power Management	OFF	OFF	Set
	5 min.		
On Start	OFF	OFF	ON
Lamp Control	Auto	Auto	Set
Pointer	Spotlight-M	Spotlight-M	Set
Remote Control	Code 1	Code 1	Set
Key Lock	None	None	Set
Fan	L2	L1	L2
Lamp Counter		Reset?	Yes
Factory Default		Return?	Yes
P-TIMER	OFF		P-TIMER

10. How to Use the PJ Controller

Parameter	Description
Language	Select the desired language from the pull-down menu.
Auto Setup.....	Automatically set PC adjustment and correct keystone distortion. Auto PC Adjust.Select "On" to automatically set the PC adjustment.
Auto Keystone	Select Auto to automatically correct keystone distortion, and select "Manual" to set keystone distortion when the Auto set button is clicked.
Keystone	Press the ▲▼ buttons to correct keystone distortion. Check the High Speed box if you wish to increase the variation. Click OFF if you do not need this function.
Blue Back.....	Select "ON" or "OFF" to display/hide blue background when no signal is detected.
Display	Select "ON", "OFF", or "Count Down Off" to display/hide the screen.
Logo Select.....	Select the image to show on the starting-up display from "User", "Default" or "OFF".
Capture	Click "YES" to capture the projected image. The captured image can be used for the starting-up display.(Select User for Logo)
Ceiling	By clicking "ON", the image gets reversed vertically and horizontally to adjust to ceiling-mount projection.
Rear	By clicking "ON", the image gets reversed horizontally to adjust to rear projection.
Terminal.....	Select "Computer 2" or "Monitor Out" from the pull-down menu.
Standby Mode	Click "Normal" or "Eco" to set the Standby Mode of the network.
No Show	By clicking "ON", the image will be temporarily hidden from view.
Freeze	By clicking "ON", the image will temporarily freeze.
Power Management	Select "Ready", "Shut Down" or "OFF" from the pull-down menu. Enter the count-down time by clicking ◀▶ buttons.
On Start	By clicking "ON", the projector will be automatically turned on when the power plug is connected to AC outlet.
Lamp Control	Select the Lamp Mode from "Normal", "Eco" and "Auto".
Pointer	Select the shape of the Pointer from "Spotlight-S", "Spotlight-M", "Spotlight-L", "Pointer", "Finger" and "Laser".
Remote Control	Select Remote Control Code from Code1 to Code 8. If you change the code here, you have to change the code of the remote control product at the same time.
Key Lock	To lock the projector, select "Projector Keys" (Locks the top panel operation)or "Remote Control" (Locks the remote control operation). If you do not need to lock, select None.
Fan	Adjust the rotating speed of the cooling fans. "L1" is normal and "L2" is slower and quieter mode.
Lamp Counter	You can reset the lamp counter. Reset the lamp counter only when you change the lamp.
Factory Default	If you wish to reset all the values you set in the control menu, click "Yes".
P-TIMER.....	When you click "P-TIMER", the timer will appear on the projected screen. Click again and the elapsed time will appear. Click again and the timer will disappear.



Service

Items on this screen are used for maintenance of the projector.

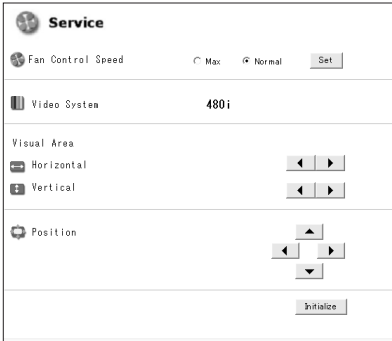

Parameter	Description
Fan Control SpeedSelect "Max" or "Normal".
Video System*Display the current video system.
Horizontal*Click ◀▶ buttons to adjust horizontal screen size.
Vertical*Click ◀▶ buttons to adjust vertical screen size.
Position*Click ◀▶▲▼ buttons to adjust the screen position.
Initialize*Reset all the service items to the factory default settings.

* If you select Wired, Wireless Computer1 (Analog / Digital) or Computer 2 (RGB) for the input source, these items are not shown.



Save Actual Adjustment

On this screen, you can save and load the setting. The items you can save are as follows: Input, PC adjustment, System Adjustment, Image Adjustment, Screen and Setting.

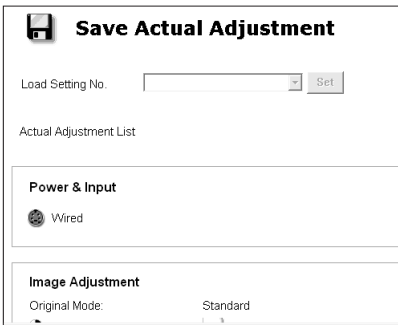

1. Confirm the actual adjustment

When you click Save icon in the Control Menu, the "Save Actual Adjustment" screen will appear. Check each setting. (Go to the next page.)

* The figure shows only a part of the full screen.

2. Select Set Number and name the setting

Select the Set Number you wish to store the adjustment from the pull-down menu.
Enter the name of the setting in the Memo field.

Store Adjustment

Save to: **Set 1** (dropdown menu with options Set 1, Set 2, Set 3, Set 4, Set 5, Set 6)

Memo: **Save**

Enter the name of the setting

3. Save the setting (Set)

Click Save button to save the adjustment.

Loading the Set

Click the pull-down menu of Load Setting No. and select the set number you wish to load.
Click Set button to display the value of the set.



Save Actual Adjustment

Load Setting No.

Set 1 (test-1) (dropdown menu with options Set 1 (test-1), Set 2 (test-2), Set 3 (test-3), Set 4 (test-4), Set 5 (test-5)) **Set**

Actual Adjustment List

Power & Input

Wired

Select the set number from the pull-down menu.

Multi Control

With this function, multiple projectors can be operated simultaneously.

You can operate up to 64 projectors at the same time.

With this function, you can also operate the projector which is attached a MultiCard Imager and on the same network.

Operation

1. Activate NetworkModule Client (or NetworkModule Moderator), and call up the Advanced Settings screen.
2. Select the projectors to operate by the mouse pointer with pressing the [Ctrl] key or the [Shift] key of the computer. The illustration of PJ Controller / Multi Control button will be changed from one projector into two projectors.
3. Click the PJ Controller / Multi Control button to display the Multi Control screen.

* When selecting only one projector in step 2, the PJ Controller screen will appear in step 3.

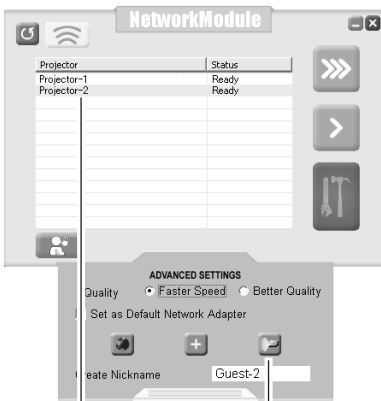

Network Projector
Select multiple projectors.

PJ Controller / Multi Control button
The illustration on the button will become two projectors.

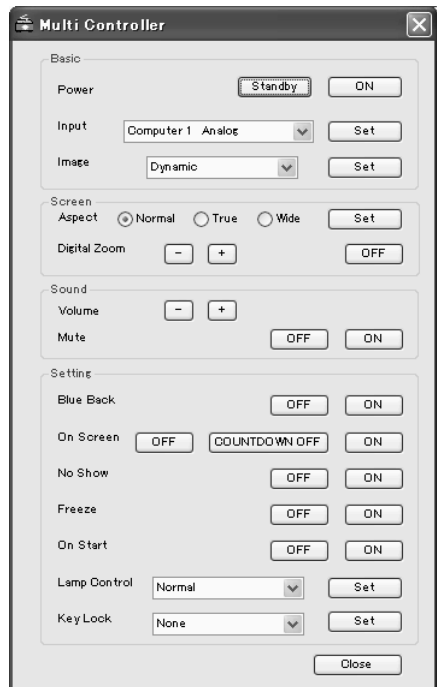

10. How to Use the PJ Controller

Parameter	Description
Power.....	Turn on or off the projector. * When using the Multi Control function, set "Normal" from "Setting menu" → "Standby mode". If selecting "Eco", you cannot turn on the projector again after turning off.
Input.....	Select projector input.
Image.....	Select Image mode.
Aspect	Select aspect of the screen.
Digital Zoom.....	Zoom in or out the screen.
Volume.....	Adjust the volume of the speaker on the projector.
Mute	On or Off the Mute function.
Blue Back.....	Select "ON", to project blue screen when the input source is not detected.
On Screen	Select to display or not to display the On screen menu.
No Show	Select "ON" to display the blank screen.
Freeze	On or off the Freeze function.
On Start	Select to turn on or off the projector with the projector power source.
Lamp Control	Select the brightness of the screen.
Key Lock	Lock or Unlock the key operation of the projector and the remote control.
* Items with "SET" button requires to click "SET" to be effective.	
NOTE :Items to adjust differ depending on the projector. With some projectors these functions may not work properly.	

11. Appendix

- Troubleshooting
- Terminology
- Setting up IP Address with arp + ping Command

11. Appendix

Troubleshooting

If you have any trouble in setup or operation of the projector, refer to the troubleshooting items and check the relevant matters described.

■ The computer cannot connect projectors.

Wired LAN

- Is the LAN cable connected to the projector properly?
- Are the Link lamp and Access lamp of the LAN terminal lighting properly?
 - Not lighting : The LAN setting of the projector is set "On"?
 - See "Wired LAN setting" in the projector menu.
 - The LAN cable is connected to the network HUB properly?

Wireless LAN

- Is the USB Wireless LAN Adapter attached to the USB terminal of the projector and USB lamp is blinking? If there are not any problems, confirm the LAN setting again.
- If the computer supports Wireless LAN, activate NetworkModule Client (or NetworkModule Moderator) and try to connect with the Easy setting button. Refer to "5. Wireless LAN configuration" → "Easy settings" (p36, 37)

■ Wireless LAN Connection cannot be established.

AdHoc Mode:

When selecting LAN4(factory default setting)

Check each item in the Wireless Setting menu of the projector as follows:

- *IP AddressIs the address appropriate? Should not be same as the other IP address.
- *Sub netShould be the factory default value, 255.255.0.0.
- *GatewayShould be the factory default value, 255.255.255.255
- *Network Type....Should be Ad-Hoc mode
- *ESSID/SSID/IBSSID
.....Should be the same as the setting of computer
->Check the setting for the computer
- *Is the Wireless channel set as 11 both for the computer and the projector?
->The factory default channel of the projector is 11.
- *WEP (Wired Equivalent Privacy)
.....Should be disabled.
To enable the function, set the WEP by the browser after the connection is established.
(Refer to 6. Configurations with Browser (p47).)

Infrastructure Mode:

When selecting LAN5 (factory default setting)

Check each item below in the Wireless Setting menu of the projector as follows:

- * IP AddressNo setting is required.
- * Sub netShould be same as the setting of the access point
- * Gateway.....Should be same as the setting of the access point
- * Network TypeShould be the Infrastructure mode
- * ESSID/SSID/IBSSID....Should be same as the setting of the access point

Check the settings for projector Client computer

- * IP AddressNo setting is required. Automatically set as HDCP.
- * Wireless Channel.....Should be 11
- * ESSID/SSID/IBSSID....Is same as the setting of the access point?
- * WEP.....Should be disabled.
->To enable the function, set the WEP by the browser after the connection is established.(Refer to 6. Configurations with Browser (p47).)

* When using LAN5, it is necessary DHCP/BOOTP server is under the environment enabling those servers communicate through networks. Some access points may have the DHCP function. For detail of the settings, refer to the owner's manual for the devices or consult a system administrator of the network.

Is the segment where the projector is installed different from the computer?

Specify IP Address directly on the optional setting. Refer to "4. Wired LAN Configuration" → "Confirming the Operation" (p28, 29).

■ Connection between computer and the projector via Wired LAN cannot be established.

When selecting LAN1 (factory default setting)

Check IP address, Sub net and Gateway of the projector and computer. For further details of the configuration, contact your system administrator.

Is the segment where the projector is installed different from the projector?

Specify IP Address directly on the optional setting. Refer to "4. Wired LAN Configuration" → "Confirming the Operation" (p28, 29).

About Settings for LAN Environment:

When setting LAN4 or LAN5, first, connect to the projector with easy settings and set with the browser. Or connect client computer to the projector in accordance with the factory default settings. Make detailed settings by the browser and then restore the computer for previous environment setting.

■ **Cannot start up the browser**

Is connection between PC and the projector with NetworkModule Client (or NetworkModule Moderator) established?

No.....Check settings for Wireless/Wired LAN.

YesCheck settings of the proxy setting at browser. Refer to "6. Browser Configurations" (P 40)

■ **Although connection between PC and the projector is established, images are not projected on the screen.**

Make sure Wireless/ Wired is selected from the Input source menu of the projector.

■ **The projector / PJ Controller cannot be turned on/off.**

Make sure the settings of the projector are correct to use the projector with it.

Refer to "10. How to Use the PJ Controller" → " Power and Status" (p78, 79).

■ **Network Viewer does not work with the projector operation.**

Make sure the FTP server setting. You need to set the FTP server in advance.

Refer to "9. How to Use Network Viewer" → "3)Operating with the projector". (p70, 71)

■ **Speed of playing back images are very slow.**

When connecting on AdHoc mode, check which Wireless channel you are using.

If the computer using the same channel as yours is existing closely, the networking speed may be diminished or the communication unstable. Change channel to resolve the problem.

The channels of the projector and projector Client computer must be the same. Or adjust the Quality selection in the Advanced settings.

Refer to "7. Project the Image via the Networks"(p56).

■ **Wired / Wireless input cannot be changed.**

NetworkModule Client (or NetworkModule Moderator) cannot be operated.

Press the Reset button on the back of the projector to restart the projector.

Caution: After selecting "Setting menu" → " Initial settings" in the projector menu, all the projector and network settings you have made (such as password or projector name etc.) will go back to the factory default settings.

Terminology

DHCP server (Dynamic Host Configuration Protocol)

It is necessary to set an IP address for each computer or equivalent equipment when establishing a network by TCP/IP. If there exists DHCP server on the network, it will assign IP addresses to client computers every time they request it. If there exists equipment with DHCP server functions (such as a Windows 2000 server and a dial-up router) on the network, the DHCP server function may be automatically operating. Ask your system administrator whether the DHCP server is operating.

ESSID (Extended Service Set Identifier)

ESSID is the ID that is set to computers on Wireless LAN or access point in order to prevent each computer from being crossed. The computers or access point to which the same ESSID is set can communicate with each other. If an ESSID is different, it is impossible to communicate. ESSID distinguishes between lowercase and uppercase characters, and allows you to use English one byte characters and half-size symbols up to 32 characters.

WEP (Wired Equivalent Privacy)

WEP is a security protocol for Wireless LAN. It protects computers on Wireless LAN and access point from unauthorized access by setting a description code onto them. It is necessary to set the same decryption code for equipment.

Wi-Fi (the Standard for Wireless Fidelity)

Wi-Fi is short for Wireless fidelity and a marketing brand name for IEEE 802.11b High-Rate. Only the products that have passed an inter-operation test carried by WECA is approved as Wi-Fi. Any products approved as Wi-Fi are certified as interoperable with each other by WECA. It is recommended to use the products approved by Wi-Fi when introducing network equipment such as local area network.

Wireless Channel

It is necessary to divide frequency spectrums into some Wireless channels for Wireless communication, and to tune to the same channel between Wireless equipment. If you use the same channel on the same floor, and there are some Wireless LANs that have a different ESSID for each, the communication speed may become slow. In this case, using different channels for each Wireless LAN is effective, and lowers a possibility of mutual interference between Wireless LANs

WECA (Wireless Ethernet Compatibility Alliance)

WECA is an organization promoting IEEE802.11b High -Range standard and assuring the compatibility of products that meet the standard.

MAC address (Media Access Control Address)

MAC address is a physical address for every network interface. The MAC address consists of 6-byte hex number. The first 3 bytes are a Vendor ID controlled and assigned by IEEE. . The last 3 bytes are controlled and assigned by the manufacturers of network interface. (no duplication of MAC address) Therefore, MAC address is a unique physical address in the world. Ethernet sends and receives frames on the basis of MAC address.

Setting up the IP address with “arp” + “ping” command

You can use “arp” and “ping” command from Command Prompt to assign an IP address to your projector.

1. Start up projector and configure the Wired or Wireless LAN to communicate with the computer.
2. From Windows "Start" menu, click "Run". In the field next to "Open:", enter “command” and click OK. When “MS-DOS prompt” (or command prompt) appears, type in “arp” command as follows:

(Example)

```
C:\> arp -s 169.254.1.100 00-c0-6f-05-1c-c2
```

—— Indicates an IP address you wish to assign to your projector.

----- Separates MAC address of your projector product every two characters by hyphen.

MAC address is indicated on a label attached to the bottom of each unit.

3. Next, enter “ping” command as follows:

(Example)

```
C:\> ping 169.254.1.100 (by executing ping command, the IP address will be set)
```

—— Indicates an IP address you wish to assign to your projector.

Reply from 169.254.1.100:bytes=32 times=2ms TTL=255

(if this message appears, the IP address was successfully assigned to projector)

Note: The assigned IP address is saved in the firmware of projector, thus it will remain set even when the power is off. You can use the same method to re-assign an IP address.

If 'arp+ping' option ("6, Configurations with Browser" → "Advanced Setup" → "TCP/IP" (p46)) is disabled in TCP/IP setting of the projector, you cannot assign an IP address using “arp” and “ping” commands. (In factory default state, "arp+ping" is set to “Enable”).

